

Planning Guide



Panorama Home Elevator

This planning guide is designed to assist architects, contractors, home owners and elevator professionals in planning for a **Home Elevator** to meet the requirements of CAN/CSA.

We strongly recommend that you contact the code authority having jurisdiction in the area(s) where the elevator will be installed to become familiar with all the legal requirements governing the installation and use of elevators in private residences. It is extremely important for you to know and adhere to all regulations pertaining to the installation and use of elevators

This Planning Guide provides nominal dimensions and specifications useful for the initial planning of an elevator project. Before beginning actual construction make sure to receive application drawings customized with specifications and dimensions for your specific project.

DO NOT CONSTRUCT THE RETURN WALLS ON EITHER SIDE OR ABOVE ENTRANCES UNTIL AFTER WE HAVE ALIGNED THE DOORS AND FRAME ON SITE.

General Specifications

G1 The design and construction of all work is to conform to the local applicable building code.

G2 Read these drawings in conjunction with all related architectural, mechanical, electrical, and elevator drawings as well as any other contract documents.

G3 The wall drawings have been prepared using engineering principles and the design loads that are applied by the elevator rails to the wall. However, the details and member sizes and the

attachments to the structure should not be construed as a complete design of the wall system. The contractor and/or the project engineer is responsible to evaluate the other loads that are applied to the wall from the floor or roof system and modify member sizes or connections as required by their analysis.

The fused disconnect switch rating and fuse rating for the lift will be shown on the shop drawings forwarded for your project. **FOR ALL HYDRAULIC ELEVATORS WHERE EMERGENCY POWER IS SUPPLIED FROM A SECOND SOURCE FOR LOWERING THE CAR ONLY. THE DISCONNECTION MEANS SHALL BE PROVIDED WITH AN AUXILIARY CONTACT THAT IS POSITIVELY OPENED MECHANICALLY, (i.e. the opening not being solely dependent on springs), AND CONNECTED IN THE CONTROL CIRCUIT TO PREVENT MOVEMENT OF THE CAR WHEN THE DISCONNECTING MEANS IS OPEN.** Refer also to SECTION 38036 (3) OF THE **CSA** STANDARD C221-1990, ELECTRICAL CODE.

LOCKABLE FUSE DISCONNECT WITH AUXILIARY CONTACT AND A 110V DISCONNECT

When considering such items as tile flooring or other custom add-ons, care should be taken not to add more than 150 pounds to the overall weight of the lift.

Shop drawings take 1 -2 weeks after you place your order with us; the unit will be shipped 4-6 weeks.

We trust the above will be useful, but please contact us by phone or e-mail if you have any further questions.

PANORAMA, RENAISSANCE OR LEGACY RESIDENTIAL ELEVATOR

NOTES:

1. PIT TO BE LEVEL, DRY AND FREE OF DEBRIS
2. PIT LOAD: 3800 LBS OR 17KN (DOUBLED FOR IMPACT)
3. PIT MUST BE THE SAME WIDTH AND LENGTH AS THE HOISTWAY

PIT CONSTRUCTION

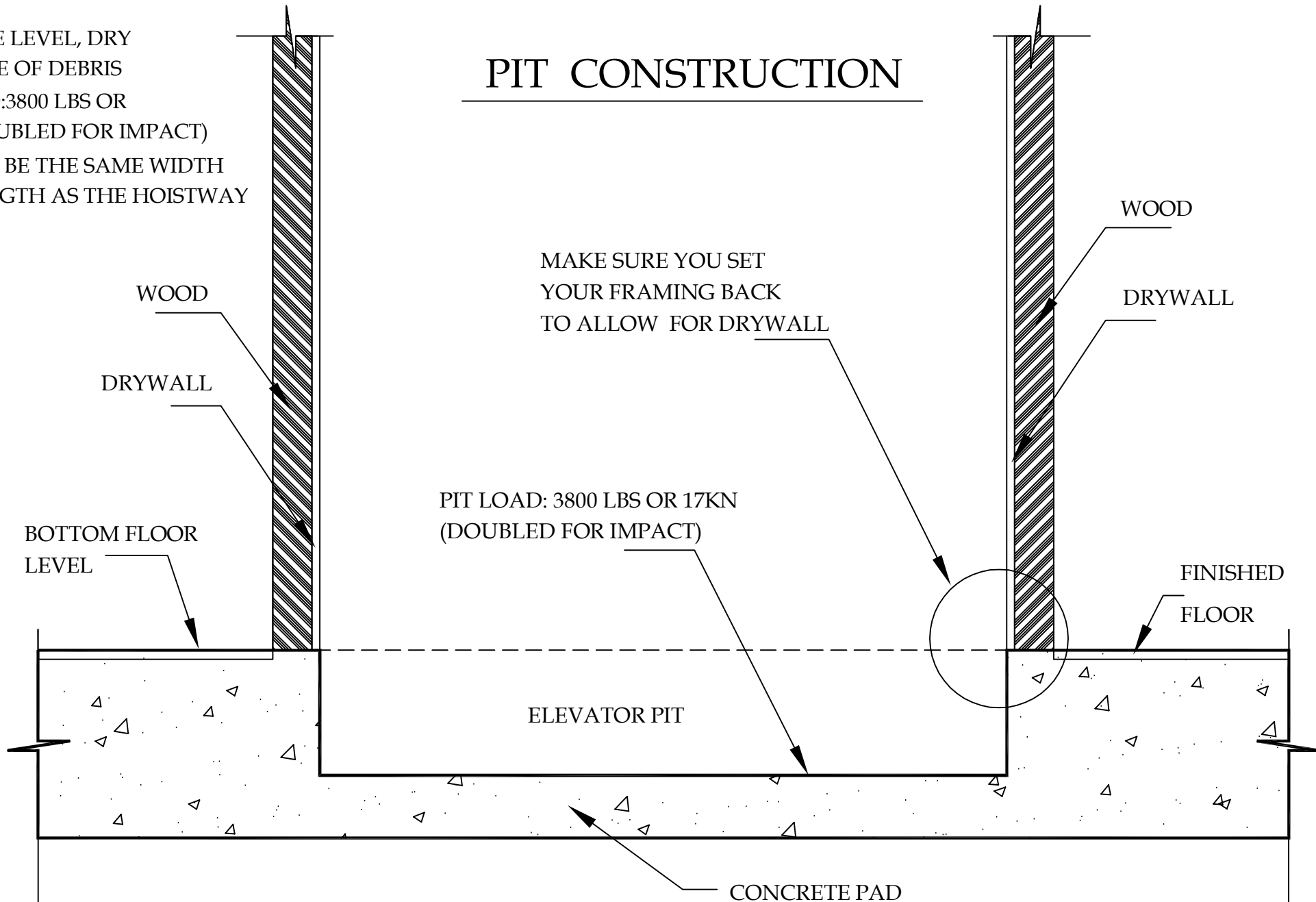

27" D.B.G. RAIL BRACKET

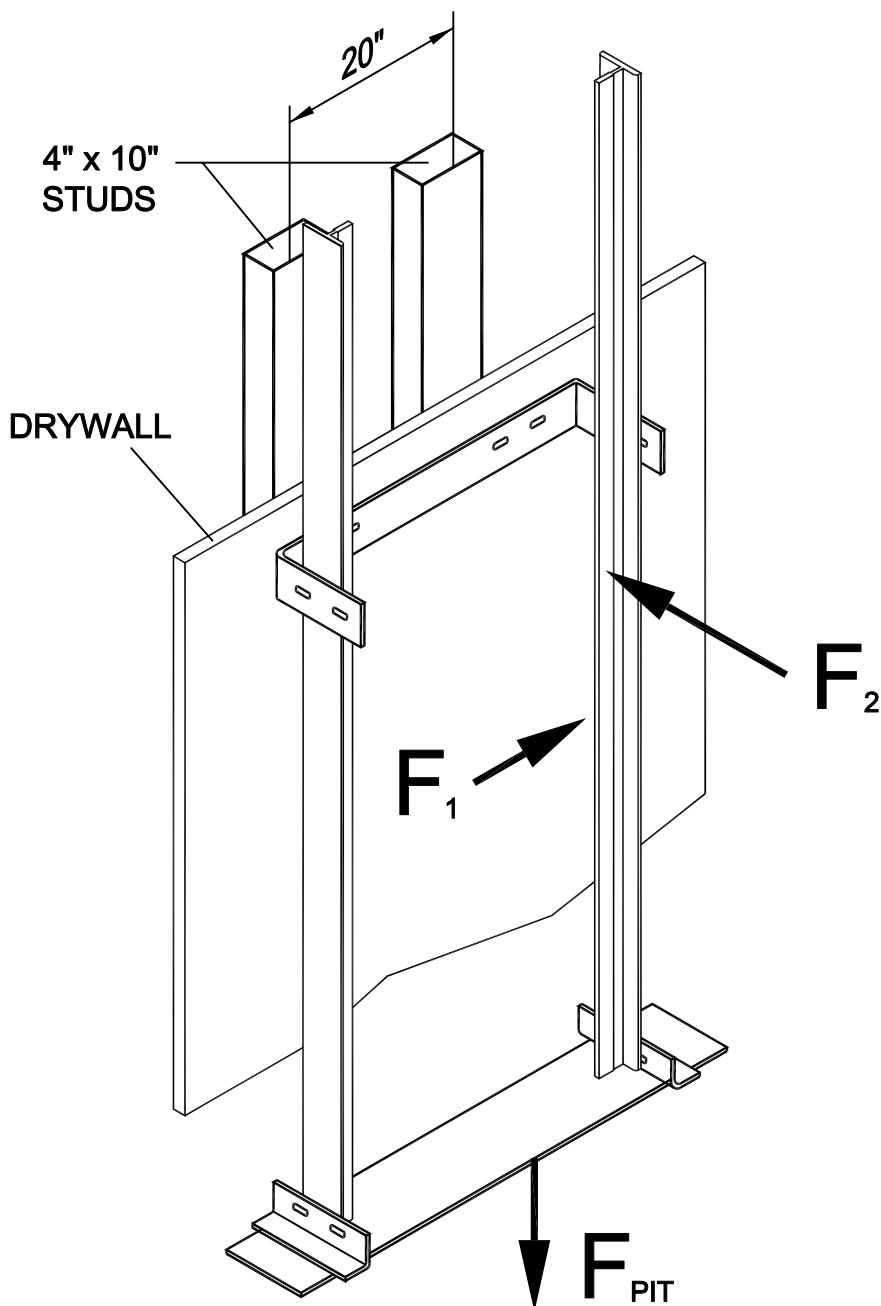
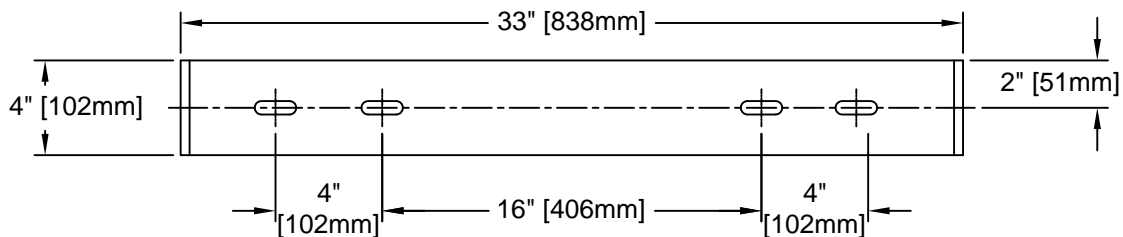

43 WENTWORTH COURT
 BRAMPTON, ONTARIO, CANADA L6T 5L4
 TEL: (905) 458-4015
 1 (888) 785-5438 (LIFT)
 FAX: (905) 458-0680
 www.federalelevator.com
 E-MAIL: sales@federalelevator.com

LOAD	DESCRIPTION	LB _f [KN]
F_{PIT}	Load Imposed on Pit Floor (Including Impact)	3825 [17.0]
F_1	Force on Rail	225 [1.0]
F_2	Force on Rail	675 [3.0]

RAIL BRACKET DETAIL ROPED

DIMENSIONS SHOWN BELOW ARE CORRECT FOR INSTALLATION PURPOSES.

CRITICAL DIMENSIONS ARE:

- 1) WALL TO CENTRE OF CYL. = 5 1/2" (140)
- 2) WALL TO CENTRE OF RAIL = 5 1/2" (140)
- 3) WALL TO CAB = 10" (254)

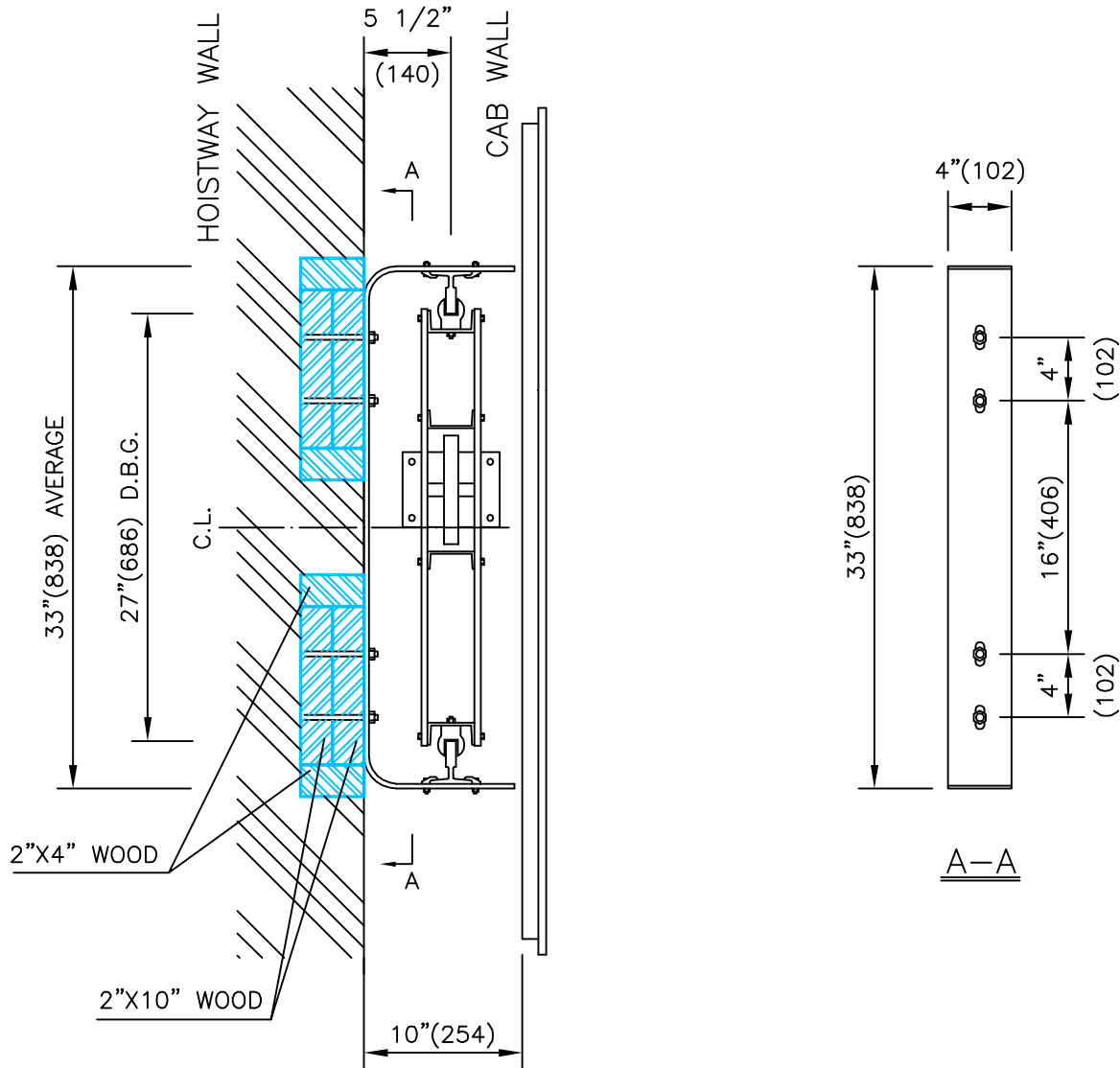

FEDERAL ELEVATOR SYSTEMS INC.
BRAMPTON, ONTARIO, CANADA

WEBSITE: www.federalelevator.com

PHONE: (905) 458-4015 FAX: (905) 458-0680

RAIL BRACKET DETAIL ROPED

DIMENSIONS SHOWN BELOW ARE CORRECT FOR INSTALLATION PURPOSES.

CRITICAL DIMENSIONS ARE:

- 1) WALL TO CENTRE OF CYL. = 5 1/2" (140)
- 2) WALL TO CENTRE OF RAIL = 5 1/2" (140)
- 3) WALL TO CAB = 10" (254)

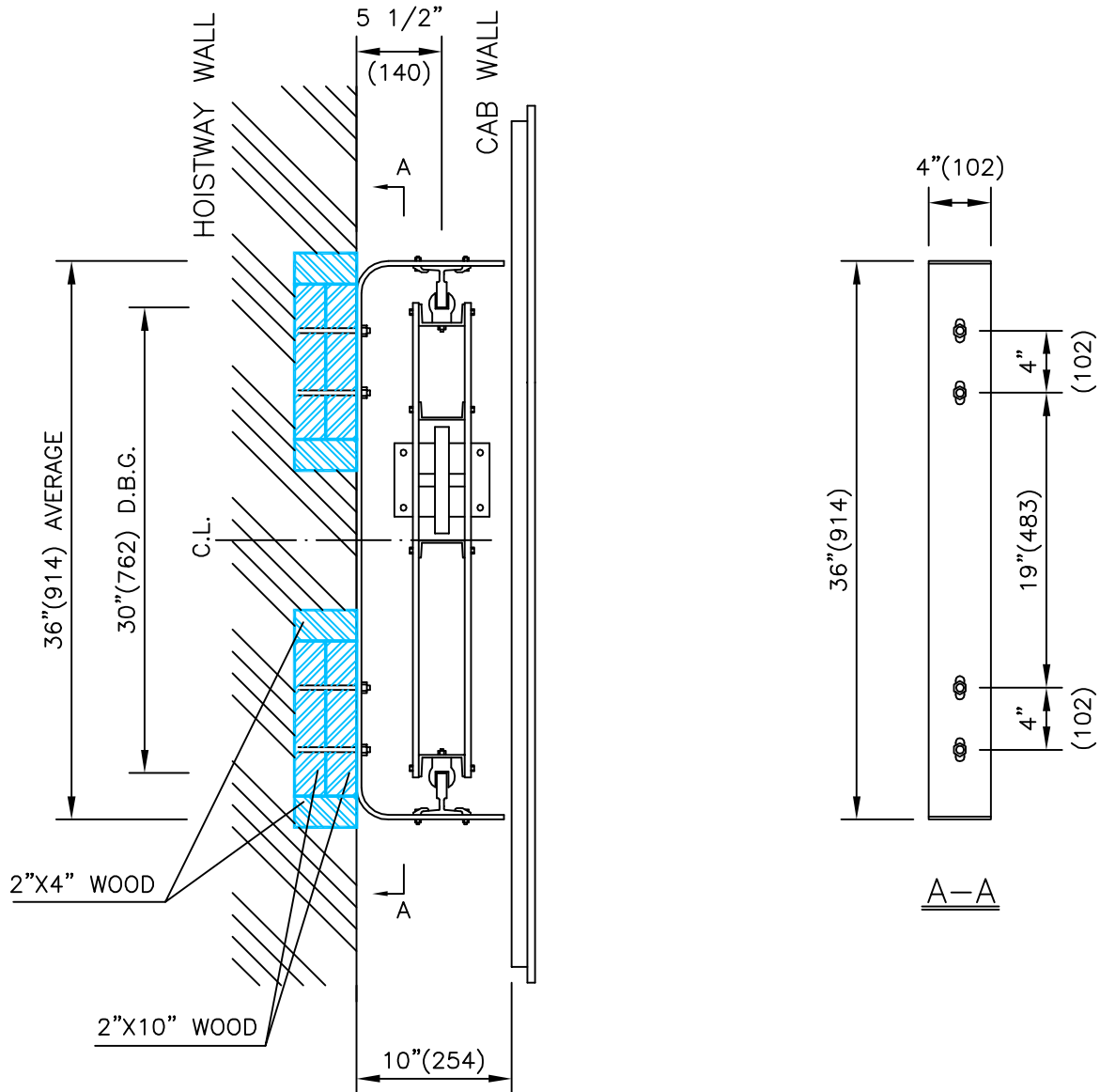

FEDERAL ELEVATOR SYSTEMS INC.
BRAMPTON, ONTARIO, CANADA

WEBSITE: www.federalelevator.com

PHONE: (905) 458-4015 FAX: (905) 458-0680

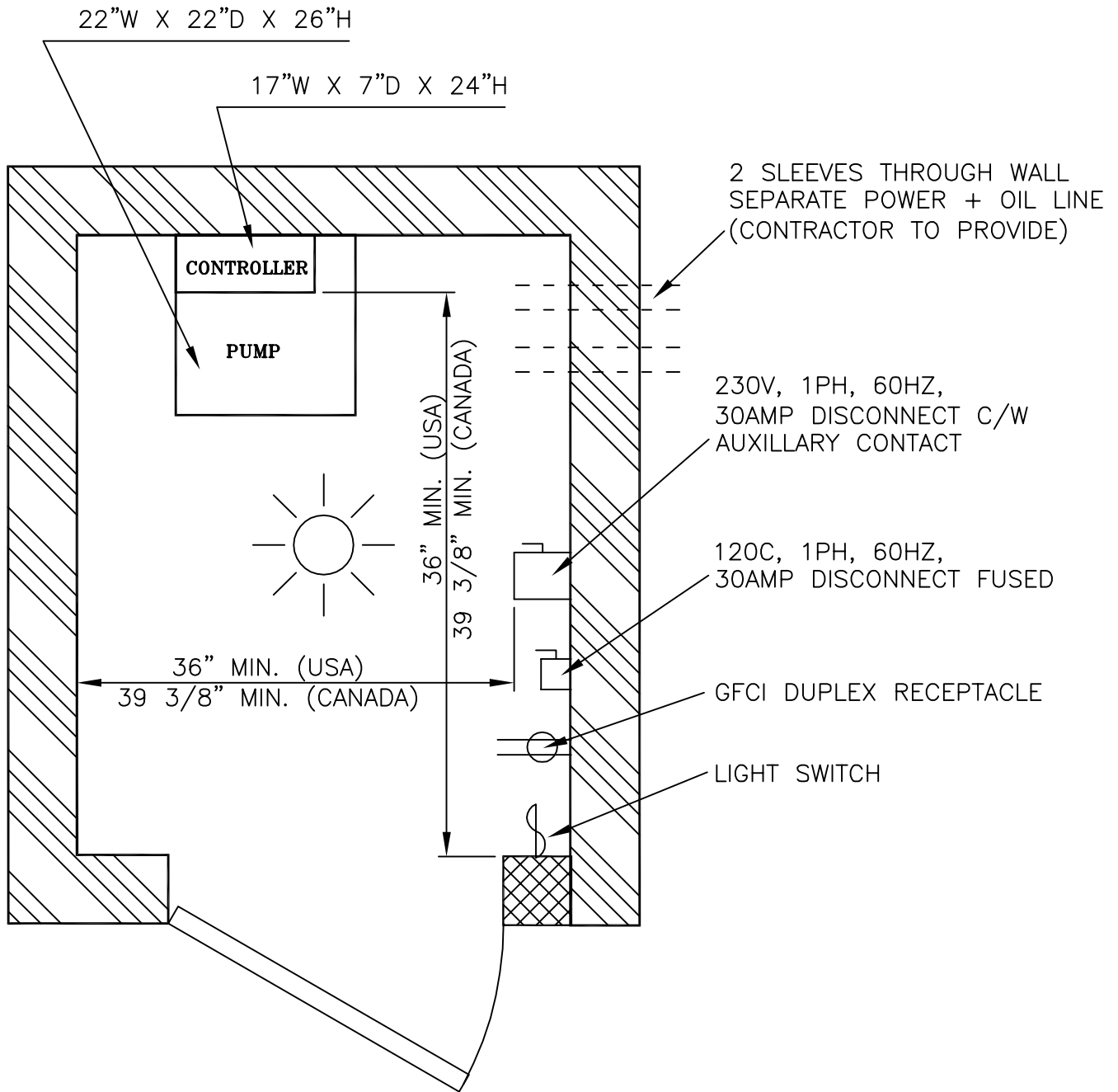

FEDERAL
ELEVATOR
Advanced Elevator Systems

43 Wentworth Court
Brampton, Ontario
Canada, L6T 5L4
Tel.: (905) 458-4015
1 (888) 785-5438 (LIFT)
Fax: (905) 458-0680
www.FederalElevator.com

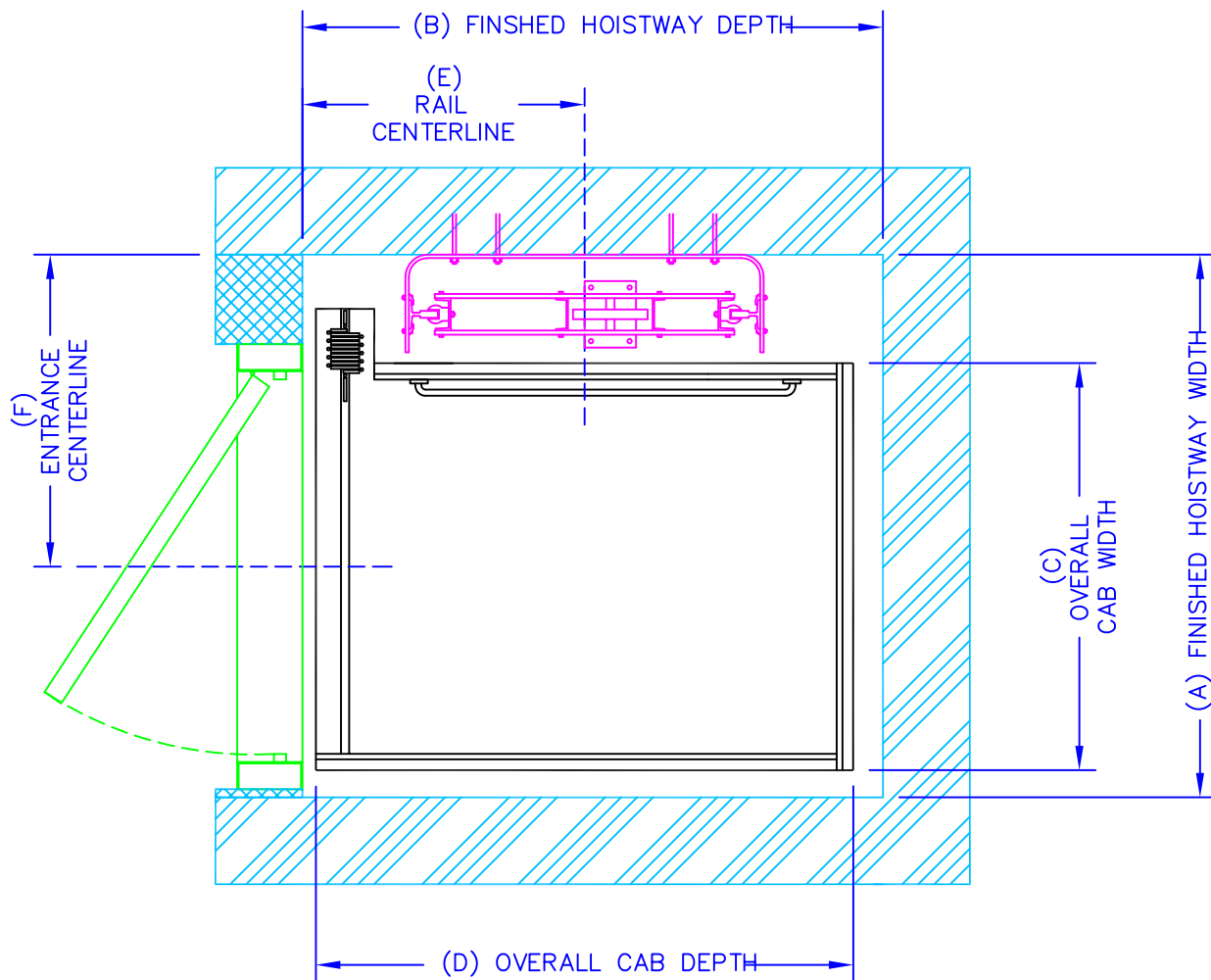

PANORAMA TYPE A LEFT

CAB SIZE	A	B	C	D	E	F
36"x48" (915x1220)	50" (1270)	53 1/2" (1360)	37 1/2" (950)	49 1/2" (1255)	26" (660)	28 3/4" (730)
36"x54" (915x1375)	50" (1270)	59 1/2" (1510)	37 1/2" (950)	55 1/2" (1410)	29" (735)	28 3/4" (730)
36"x60" (915x1525)	50" (1270)	65 1/2" (1665)	37 1/2" (950)	61 1/2" (1560)	32" (815)	28 3/4" (730)
40"x54" (1015x1375)	54" (1375)	59 1/2" (1510)	41 1/2" (1055)	55 1/2" (1410)	29" (735)	32 3/4" (830)
42"x60" (1065x1525)	56" (1425)	65 1/2" (1665)	43 1/2" (1105)	61 1/2" (1560)	32" (815)	34 3/4" (885)
48"x60" (1220x1525)	61" (1550)	65 1/2" (1665)	48 1/2" (1230)	61 1/2" (1560)	32" (815)	39 3/4" (1010)



**FEDERAL
ELEVATOR**

43 WENTWORTH COURT
BRAMPTON, ONTARIO, CANADA L6T 5L4
TEL: (905) 458-4015
1 888 785-5438 (LIFT)
FAX: (905) 458-0680
www.federalelevator.com
E-MAIL: sales@federalelevator.com

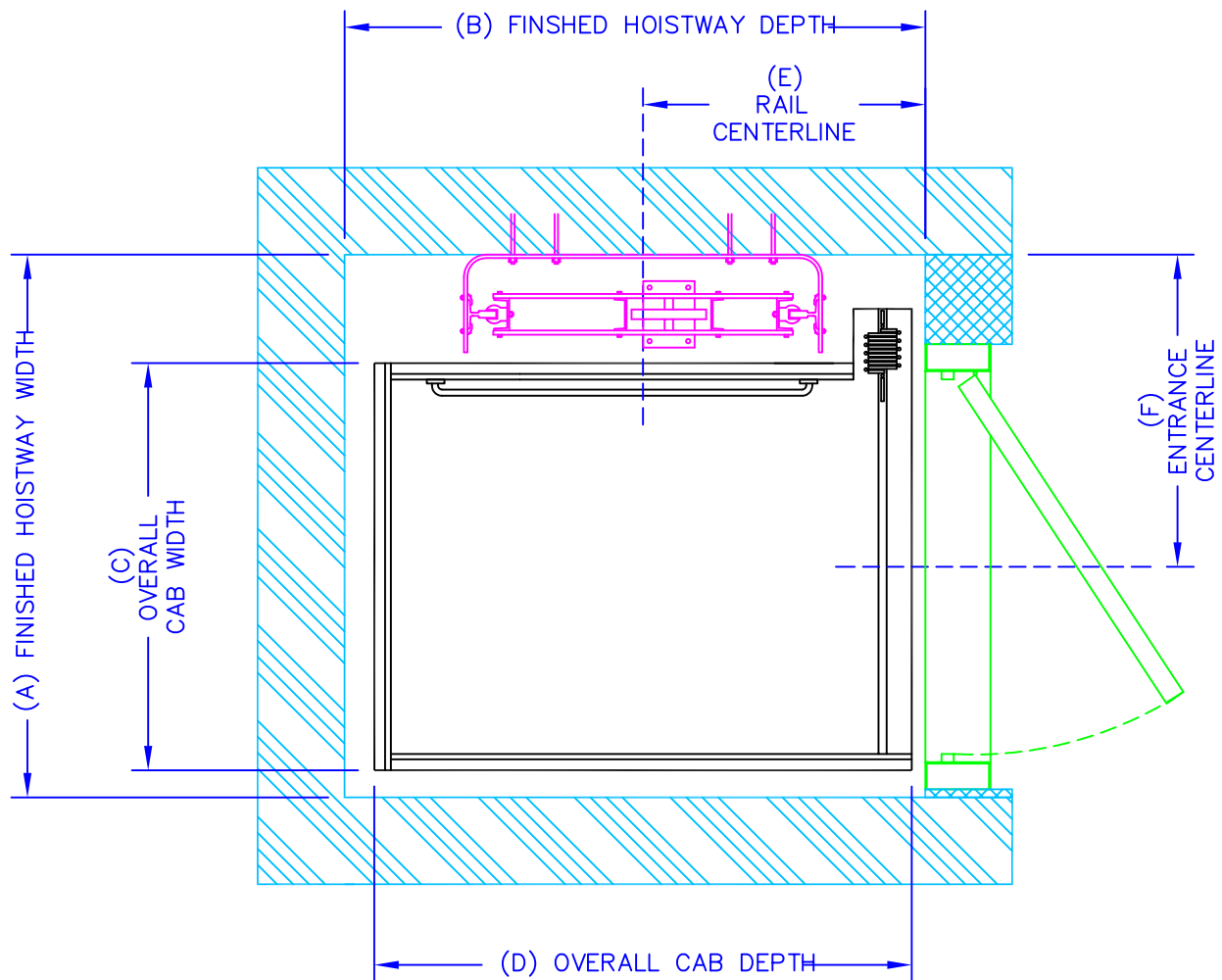

PANORAMA TYPE A RIGHT

CAB SIZE	A	B	C	D	E	F
36"x48" (915x1220)	50" (1270)	53 1/2" (1360)	37 1/2" (950)	49 1/2" (1255)	26" (660)	28 3/4" (730)
36"x54" (915x1375)	50" (1270)	59 1/2" (1510)	37 1/2" (950)	55 1/2" (1410)	29" (735)	28 3/4" (730)
36"x60" (915x1525)	50" (1270)	65 1/2" (1665)	37 1/2" (950)	61 1/2" (1560)	32" (815)	28 3/4" (730)
40"x54" (1015x1375)	54" (1375)	59 1/2" (1510)	41 1/2" (1055)	55 1/2" (1410)	29" (735)	32 3/4" (830)
42"x60" (1065x1525)	56" (1425)	65 1/2" (1665)	43 1/2" (1105)	61 1/2" (1560)	32" (815)	34 3/4" (885)
48"x60" (1220x1525)	61" (1550)	65 1/2" (1665)	48 1/2" (1230)	61 1/2" (1560)	32" (815)	39 3/4" (1010)



**FEDERAL
ELEVATOR**

43 WENTWORTH COURT
BRAMPTON, ONTARIO, CANADA L6T 5L4
TEL: (905) 458-4015
1 888 785-5438 (LIFT)
FAX: (905) 458-0680
www.federalelevator.com
E-MAIL: sales@federalelevator.com

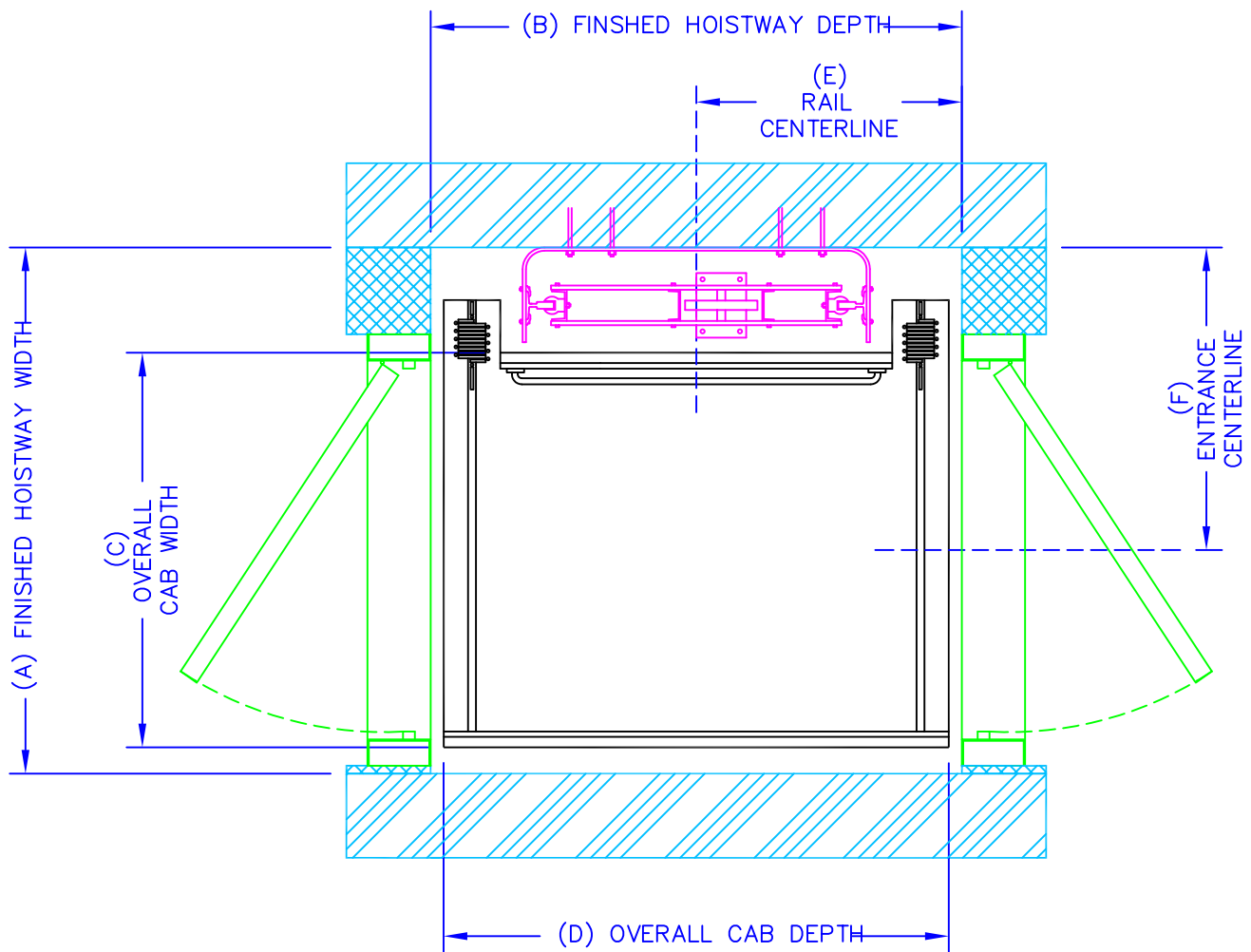

PANORAMA TYPE B

CAB SIZE	A	B	C	D	E	F
36"x48" (915x1220)	50" (1270)	50 1/2" (1285)	37 1/2" (950)	48" (1220)	25 1/4" (640)	28 3/4" (730)
36"x54" (915x1375)	50" (1270)	56 1/2" (1435)	37 1/2" (950)	54" (1370)	28 1/4" (720)	28 3/4" (730)
36"x60" (915x1525)	50" (1270)	62 1/2" (1590)	37 1/2" (950)	60" (1525)	31 1/4" (795)	28 3/4" (730)
40"x54" (1015x1375)	54" (1375)	56 1/2" (1435)	41 1/2" (1055)	54" (1370)	28 1/4" (720)	32 3/4" (830)
42"x60" (1065x1525)	56" (1425)	62 1/2" (1590)	43 1/2" (1105)	60" (1525)	31 1/4" (795)	34 3/4" (885)
48"x60" (1220x1525)	61" (1550)	62 1/2" (1590)	48 1/2" (1230)	60" (1525)	31 1/4" (795)	39 3/4" (1010)



43 WENTWORTH COURT
BRAMPTON, ONTARIO, CANADA L6T 5L4
TEL: (905) 458-4015
1 888 785-5438 (LIFT)
FAX: (905) 458-0680
www.federalelevator.com
E-MAIL: sales@federalelevator.com

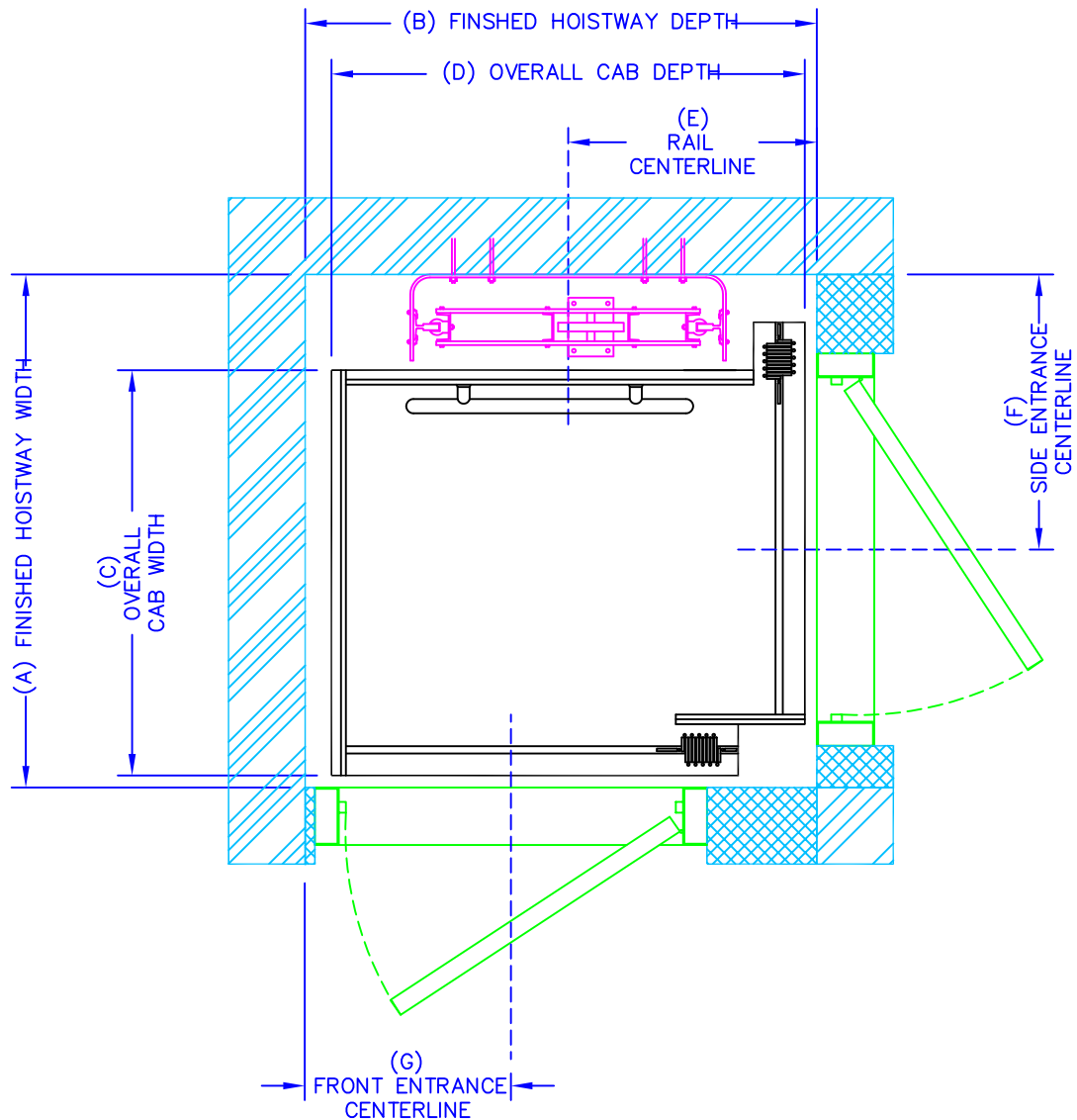

PANORAMA TYPE C

CAB SIZE	A	B	C	D	E	F	G
36"x48" (915x1220)	53 5/8" (1360)	53 1/2" (1360)	42 3/8" (1075)	49 1/2" (1255)	26" (660)	28 3/4" (730)	21 1/2" (545)
36"x54" (915x1375)	53 5/8" (1360)	59 1/2" (1510)	42 3/8" (1075)	55 1/2" (1410)	29" (735)	28 3/4" (730)	21 1/2" (545)
36"x60" (915x1525)	53 5/8" (1360)	65 1/2" (1665)	42 3/8" (1075)	61 1/2" (1560)	32" (815)	28 3/4" (730)	21 1/2" (545)
40"x54" (1015x1375)	57 5/8" (1465)	59 1/2" (1510)	46 3/8" (1180)	55 1/2" (1410)	29" (735)	32 3/4" (830)	21 1/2" (545)
42"x60" (1065x1525)	59 5/8" (1515)	65 1/2" (1665)	48 3/8" (1230)	61 1/2" (1560)	32" (815)	34 3/4" (885)	21 1/2" (545)
48"x60" (1220x1525)	65 5/8" (1665)	65 1/2" (1665)	54 3/8" (1380)	61 1/2" (1560)	32" (815)	40 3/4" (1035)	21 1/2" (545)



43 WENTWORTH COURT
BRAMPTON, ONTARIO, CANADA L6T 5L4
TEL: (905) 458-4015
1 888 785-5438 (LIFT)
FAX: (905) 458-0680
www.federalev.com
E-MAIL: sales@federalev.com

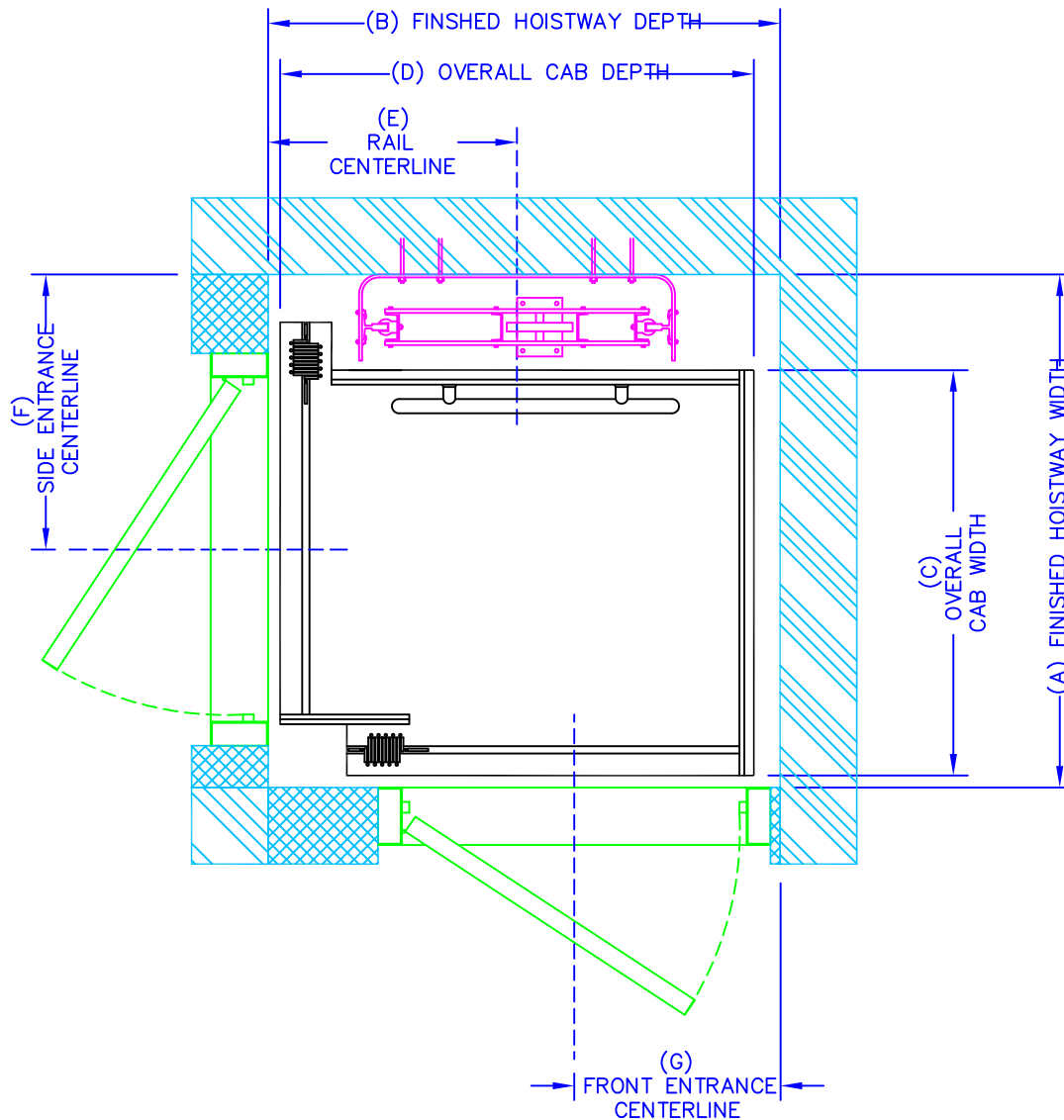

PANORAMA TYPE D

CAB SIZE	A	B	C	D	E	F	G
36"x48" (915x1220)	53 5/8" (1360)	53 1/2" (1360)	42 3/8" (1075)	49 1/2" (1255)	26" (660)	28 3/4" (730)	21 1/2" (545)
36"x54" (915x1375)	53 5/8" (1360)	59 1/2" (1510)	42 3/8" (1075)	55 1/2" (1410)	29" (735)	28 3/4" (730)	21 1/2" (545)
36"x60" (915x1525)	53 5/8" (1360)	65 1/2" (1665)	42 3/8" (1075)	61 1/2" (1560)	32" (815)	28 3/4" (730)	21 1/2" (545)
40"x54" (1015x1375)	57 5/8" (1465)	59 1/2" (1510)	46 3/8" (1180)	55 1/2" (1410)	29" (735)	32 3/4" (830)	21 1/2" (545)
42"x60" (1065x1525)	59 5/8" (1515)	65 1/2" (1665)	48 3/8" (1230)	61 1/2" (1560)	32" (815)	34 3/4" (885)	21 1/2" (545)
48"x60" (1220x1525)	65 5/8" (1665)	65 1/2" (1665)	54 3/8" (1380)	61 1/2" (1560)	32" (815)	40 3/4" (1035)	21 1/2" (545)



43 WENTWORTH COURT
 BRAMPTON, ONTARIO, CANADA L6T 5L4
 TEL: (905) 458-4015
 1 888 785-5438 (LIFT)
 FAX: (905) 458-0680
 www.federalevator.com
 E-MAIL: sales@federalevator.com

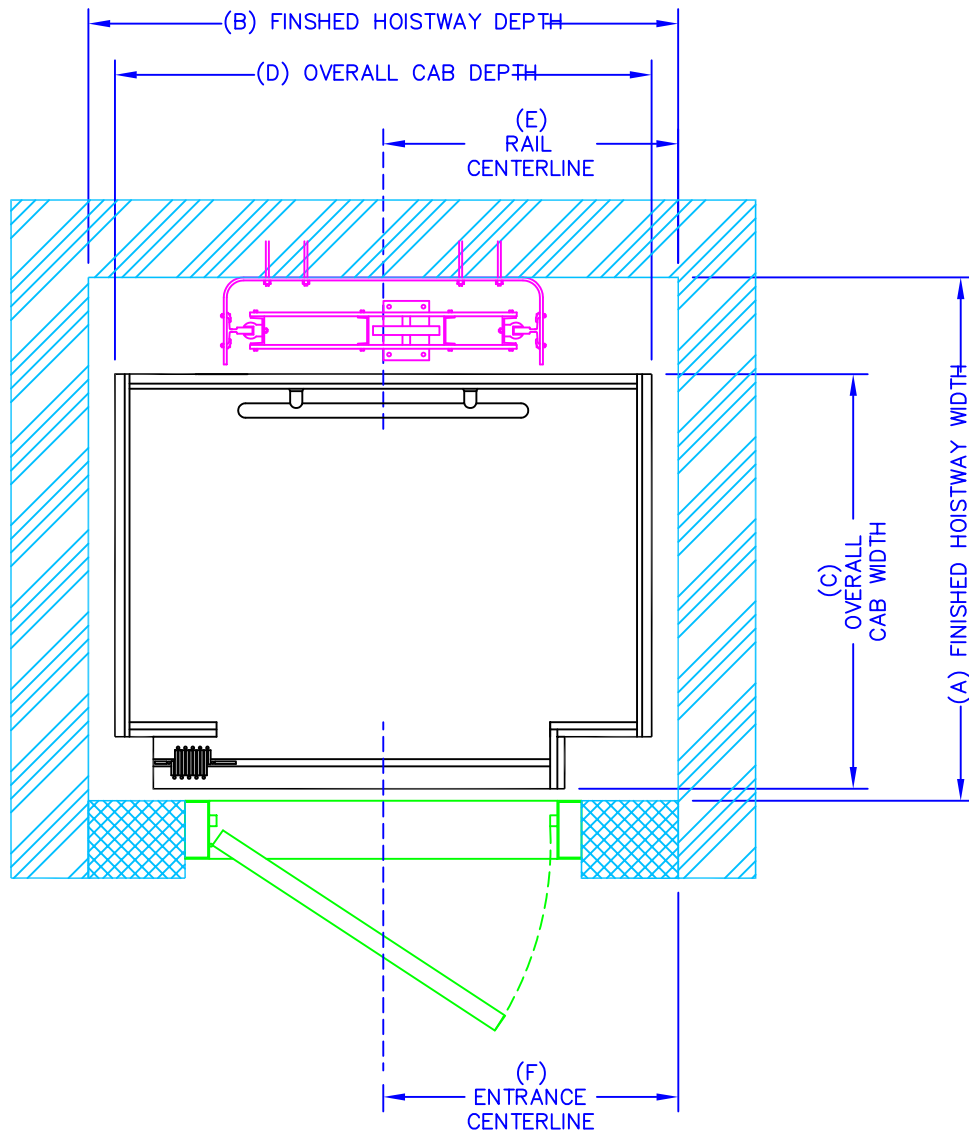

PANORAMA TYPE E

CAB SIZE	A	B	C	D	E	F
36"x48" (915x1220)	54 1/4" (1380)	55" (1400)	43" (1090)	49 1/2" (1255)	27 1/2" (700)	27 1/2" (700)
36"x54" (915x1375)	54 1/4" (1380)	61" (1550)	43" (1090)	55 1/2" (1410)	30 1/2" (775)	30 1/2" (775)
36"x60" (915x1525)	54 1/4" (1380)	67" (1700)	43" (1090)	61 1/2" (1560)	33 1/2" (850)	33 1/2" (850)
40"x54" (1015x1375)	58 1/4" (1480)	61" (1550)	47" (1195)	55 1/2" (1410)	30 1/2" (775)	30 1/2" (775)
42"x60" (1065x1525)	60 1/4" (1530)	67" (1700)	49" (1245)	61 1/2" (1560)	33 1/2" (850)	33 1/2" (850)
48"x60" (1220x1525)	66 1/4" (1685)	67" (1700)	55" (1400)	61 1/2" (1560)	33 1/2" (850)	33 1/2" (850)



**FEDERAL
ELEVATOR**

43 WENTWORTH COURT
BRAMPTON, ONTARIO, CANADA L6T 5L4
TEL: (905) 458-4015
1 888 785-5438 (LIFT)
FAX: (905) 458-0680
www.federalev.com
E-MAIL: sales@federalev.com

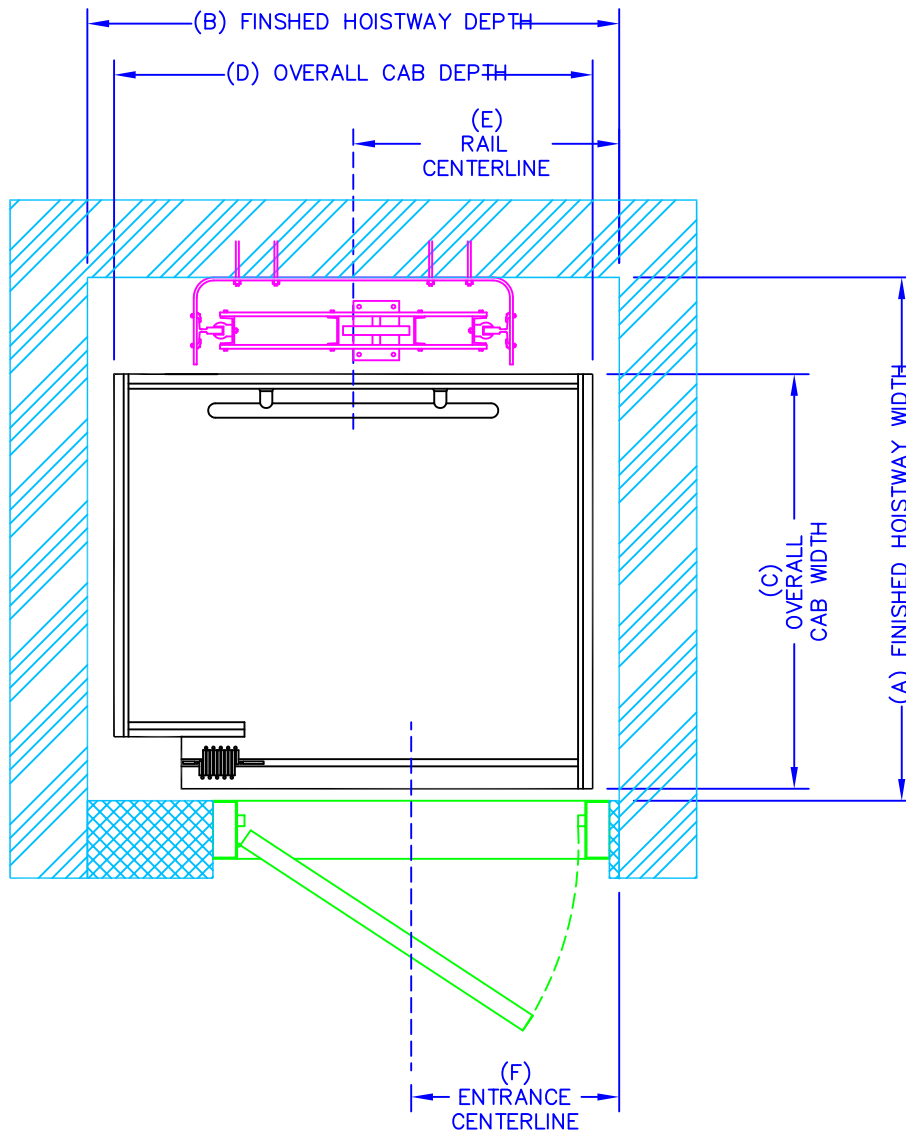

PANORAMA TYPE E RIGHT

CAB SIZE	A	B	C	D	E	F
36"x48" (915x1220)	54 1/4" (1380)	55" (1400)	43" (1090)	49 1/2" (1255)	27 1/2" (700)	21 1/2" (545)
36"x54" (915x1375)	54 1/4" (1380)	61" (1550)	43" (1090)	55 1/2" (1410)	30 1/2" (775)	21 1/2" (545)
36"x60" (915x1525)	54 1/4" (1380)	67" (1700)	43" (1090)	61 1/2" (1560)	33 1/2" (850)	21 1/2" (545)
40"x54" (1015x1375)	58 1/4" (1480)	61" (1550)	47" (1195)	55 1/2" (1410)	30 1/2" (775)	21 1/2" (545)
42"x60" (1065x1525)	60 1/4" (1530)	67" (1700)	49" (1245)	61 1/2" (1560)	33 1/2" (850)	21 1/2" (545)
48"x60" (1220x1525)	66 1/4" (1685)	67" (1700)	55" (1400)	61 1/2" (1560)	33 1/2" (850)	21 1/2" (545)



43 WENTWORTH COURT
BRAMPTON, ONTARIO, CANADA L6T 5L4
TEL: (905) 458-4015
1 888 785-5438 (LIFT)
FAX: (905) 458-0680
www.federalev.com
E-MAIL: sales@federalev.com

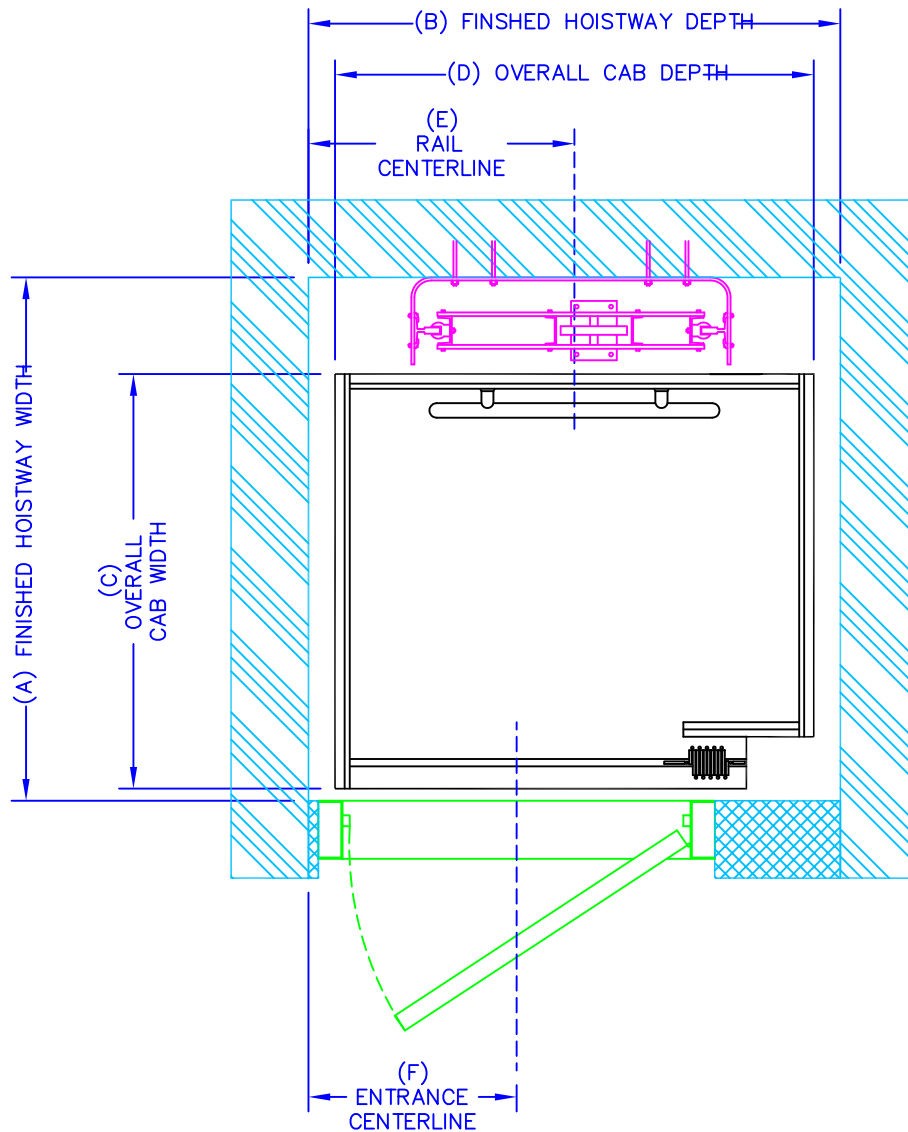

PANORAMA TYPE E LEFT

CAB SIZE	A	B	C	D	E	F
36"x48" (915x1220)	54 1/4" (1380)	55" (1400)	43" (1090)	49 1/2" (1255)	27 1/2" (700)	21 1/2" (545)
36"x54" (915x1375)	54 1/4" (1380)	61" (1550)	43" (1090)	55 1/2" (1410)	30 1/2" (775)	21 1/2" (545)
36"x60" (915x1525)	54 1/4" (1380)	67" (1700)	43" (1090)	61 1/2" (1560)	33 1/2" (850)	21 1/2" (545)
40"x54" (1015x1375)	58 1/4" (1480)	61" (1550)	47" (1195)	55 1/2" (1410)	30 1/2" (775)	21 1/2" (545)
42"x60" (1065x1525)	60 1/4" (1530)	67" (1700)	49" (1245)	61 1/2" (1560)	33 1/2" (850)	21 1/2" (545)
48"x60" (1220x1525)	66 1/4" (1685)	67" (1700)	55" (1400)	61 1/2" (1560)	33 1/2" (850)	21 1/2" (545)



43 WENTWORTH COURT
BRAMPTON, ONTARIO, CANADA L6T 5L4
TEL: (905) 458-4015
1 888 785-5438 (LIFT)
FAX: (905) 458-0680
www.federalelevator.com
E-MAIL: sales@federalelevator.com

SUGGESTED SPECIFICATIONS

Model: Panorama - Residential Elevator (Canada)

Part 1 - General

1.1 SCOPE

To furnish all labor, materials and equipment necessary or required to fully complete the installation of the elevator as indicated on the Drawings and Specifications. This suggested specification is intended to cover the complete installation of the Federal Panorama Residential Elevator.

1.2 SYSTEM DESCRIPTION

The elevator assembly shall consist of a power unit, car, guide system, 1:2 cable hydraulic lifting device, control system, signals and alarms, electrical wiring, and parts and accessories necessary to provide required performance, operation, code and safety requirements.

1.3 QUALITY ASSURANCE

1.3.1 Elevator shall meet or exceed the applicable regulations of all governing agencies and be in conformance with the Canadian Standards Associations,

- a) CAN/CSA-B44-00 Safety Code for Elevators –Part 5 Section 5.3 Private Residence Elevators.
- b) CAN/CSA B44.1/ASME A17.5 Elevator and Escalator Electrical Equipment
- c) CAN/CSA C22.1 Canadian Electrical Code
- d) National Building Code of Canada (NBC)
- e) Local Codes and regulations, as applicable.

1.3.2 Requirements of the Regulatory Agencies

- a) Fabricate and install work in compliance with all applicable jurisdictional authorities.
- b) If required by the local jurisdiction file shop drawings and submissions to local authorities as the information is made available. Company pre-inspection and jurisdictional authority inspections and permits are to be made on a timely basis as required. Work will include all inspections and re-inspections that are required to ensure licenses are issued.

1.3.3 Subcontractor Qualifications

- a) Execute work of this specification only by a contractor/company who has adequate product and public liability insurance in excess of one million dollars.
- b) Skilled tradesmen must be employees of the contractor and perform the work on a timely basis. Employees must be trained by the manufacturer and be supervised by the elevator contractor.

1.3.4 Substitutions

No substitutions will be considered unless written request for approval has been submitted by the bidder and received by the architect at least 10 days before the of receipt of bids. Each such request shall include a complete description of the proposed substitute including drawings, test data, photographs, and any other information needed for consideration.

Part 2 - Preparatory Work by Others

2.1

The following preparatory work to accommodate the elevator is to be done by others:

2.1.1

Machine room to meet applicable Codes and Standards.

2.1.2

Permanent power to operate the elevator to be provided to a lockable Fused/Cartridge Type Disconnect Switch with auxiliary contact/switch for emergency battery lowering. Refer to architectural drawings for permanent power specifications and location of disconnect switch.

2.1.3

Provide 110 VAC lighting supply and disconnect. Refer to architectural drawings for permanent power specifications and location of disconnect switch.

2.1.4

Provide an enclosed, plumb and square hoistway with smooth interior surfaces. Include for fascias or furring of hoistway interior where applicable.

2.1.5

Provide doors, frames, and door hardware

2.1.6

Provide substantial, level pit floor slab to support loads indicated on elevator contractor's shop drawings.

2.1.7

Provide adequate support for guide rail fastenings.

2.1.8

Provide pit water proofing or sump pump, if required (see elevator contractor for location).

2.1.9

Provide a 203 mm (8") minimum pit depth.

2.1.10

Provide a 2438mm (96") minimum overhead (distance from floor at upper level to underside of roof).

Part 3 - Submittals

3.1 PRESENTATION DRAWINGS

The presentation drawings shall show a complete layout of the elevator equipment detailing dimensions, clearances and location of machinery. Including the following:

- a) Drawings showing the dimensions including plans, elevations, and sections to show equipment locations.
- b) Load and reaction drawings shall be provided by the elevator manufacturer and detailed on drawings.

3.2 SAMPLES

Part 4 - Product Data

4.1 MANUFACTURER/PRODUCT

The elevator shall be the **PANORAMA** Residential Elevator manufactured by **Federal Elevator Systems** Tel: 905-458-4015 F: 905-458-0680.

Rated Load:	340 kg or 454 kg (750 lb or 1000 lb)
Rated Speed:	0.18m/s (36 fpm) nominal
Car Dimensions:	914mm W x 1220mm D (36"W x 48"D)
Operation:	Single Automatic Push Button or Non-Selective Collective
Power Supply:	220 VAC 1 Phase or 208 VAC 3 Phase
Travel Distance:	_____ (Floor to Floor) 50 feet maximum
Levels Served:	_____ (Maximum 6)
Cab Type:	___X___ as required
Lighting Supply:	110 VAC, 1 Phase, 15 Amps
Jack Type:	1:2 Cable Hydraulic
Pump Type:	"Super Hush" Dry Pump Type
Leveling Device Type:	Magnetic Tape head.

4.2 SIGNAGE

4.2.1 Each Elevator shall have all required signs, capacity plates, and data signs.

4.3 CAR ENCLOSURE

4.3.1 WALLS

½" Melamine or unfinished oak or Maple veneer wedged style car.

4.3.2 CEILINGS

Non-removable 19mm (3/4") melamine or unfinished oak or Maple veneer panel

4.3.3 FLOOR

Plywood ready to accept finished flooring by others.

4.3.4 HANDRAIL

Minimum of one (1) cylindrical or flat Stainless Steel handrail located on control wall.

4.3.5 EMERGENCY OPERATION

The car shall be equipped with a battery powered light fixture, emergency lowering device and alarm which can be actuated during normal building power supply failure. Battery will be rechargeable type with an automatic recharging system.

4.3.6 EMERGENCY LIGHT

The emergency lights shall automatically illuminate the elevator car in the event of a main power failure. Power to the emergency light will be provided by the battery back-up system.

4.3.7 CAR OPERATING PANEL

Car operating panel shall consist of one illuminated button for each landing, an emergency stop button, alarm button and a light switch mounted on a hinged brushed stainless or brass panel.

4.3.9 CAR LIGHTING

The car lighting shall consist of minimum of two (2) low voltage brass or chrome colored halogen lights. The failure of one lamp shall not cause the remaining lamps to extinguish.

4.3.10 LIGHT SWITCH

Overhead lights in the car shall be activated by a light switch mounted on the car operating panel.

4.4 DOOR INTERLOCKS

4.4.1. A door Interlock shall be provided at each door entrance, which will prevent operation of the elevator unless the hoistway door is closed and locked or prevent opening of the hoistway door from the landing unless the elevator car is within the landing zone. Located as per Federal Elevator shop drawing.

4.4.2 A solid core wood door (swing type) that protects entrance into the hoistway to be supplied and installed by Owner/Agent at each landing.

4.5 PLATFORM TOE GUARD

A platform toe guard shall be provided at each car entrance opening to extend below the car entrance opening for safety.

4.6 LEVELING DEVICE

a) The elevator shall be provided with a 2-way leveling device which will maintain the car within 13mm (½") of the landing.

b) Leveling device switches shall be located in a position to be inaccessible to unauthorized persons.

4.7 HYDRAULIC POWER UNIT

a) The motor shall be the dry type installed outside the oil tank for ease of service.

b) Pump shall be screw type specifically designed for elevator use.

c) The controller shall be integrally mounted on the power unit frame.

d) Control circuitry to be Micro Processor Controlled and be located in the controller.

e) The power unit control valve shall be a single speed control valve that has the following features:

(i) Adjustable down speed.

(ii) Up start with built-in damping.

(iii) Constant down speed regulation

(iv) Adjustable pressure relief valve.

(v) A manual operated down valve to lower elevator in an emergency.

(vi) Pressure gauge with shut off Valve.

(vii) Gate valve to isolate cylinder from pump unit

4.8 NEGATIVE PRESSURE SWITCH

In addition to the standard operating features of the hydraulic control valve, there shall be a pressure sensitive check valve that will activate when negative pressure is sensed in the hydraulic system. The check valve will close and stop the hydraulic jack from descending immediately on sensing negative pressure

4.9 CYLINDER AND PLUNGER

4.9.1 The cylinder shall be constructed of steel pipe of a sufficient thickness and suitable safety margin. The top of the cylinder shall be equipped with a cylinder head with an internal guide ring and self adjusting packing.

4.9.2 The plunger shall be constructed of a steel shaft of a proper diameter machined true and smooth. The plunger shall be provided with a stop electrically welded to the bottom to prevent the plunger from leaving the cylinder.

4.10 CABLE

Minimum of two 3/8" (10 mm) IWRC Galvanized Aircraft Cables. Minimum breaking strength of 14,400 lbs. each.

4.11 SAFETY DEVICE

A "slack/broken cable" safety device shall be supplied which will stop and sustain the elevator and its rated load, if either of the hoisting cables become slack or breaks. The safety device shall be reset table by the operation of the elevator in the upward direction. A switch shall be mounted in such a position as to sense the operation of the safety device, and will open the safety circuit to the controller to prevent operation of the elevator in either direction.

4.12 GUIDE YOKE

The 1:2 guide yoke/sheave arrangement shall be supplied with a sheave, guide shoes, roller bearings and adjustable cable guards. The sheave shall be finished with rounded grooves to fit the cables.

4.13 NORMAL TERMINAL STOPPING DEVICES

Normal terminal stopping devices shall be sensed by an encoder at the top and bottom of the runway to stop the car automatically.

4.14 FINAL LIMIT SWITCH

The elevator shall be equipped with a final limit switch to cut off all power to the elevator if the upper normal terminal stopping devices fail.

4.15 GUIDE RAILS AND BRACKETS

4.15.1 Steel "T" guide rails and brackets shall be securely fastened to the building structure.

4.15.2 Brackets shall securely hold the guides in a plumb and true position regardless of car loading.

4.15.3 Guides shall be bolted through the hoistway enclosure with back-up plates, washers and nuts. Subject to architects' alterations and approval.

4.16 CAR SLING

4.16.1 Car sling shall be fabricated from steel members with adequate bracing to support the platform and cab.

4.16.2 The striking member on the underside of the car must stop the elevator before the plunger reaches its down limit of travel.

4.16.3 Sliders to be made of resilient composite tire. Tire material to be of sufficient compressive strength to prevent deformation of the tire surface during periods of inactivity.

4.17 WIRING

All wiring and electrical connections shall comply with applicable Codes, insulated wiring shall have flame retardant and moisture proof outer covering and shall be run in conduit or electrical wire ways. Traveling cables shall be flexible and suitably suspended to relieve strain.

Part 5 - Execution

5.1 EXAMINATION

All site dimensions shall be taken to ensure that tolerances and clearances have been maintained and meet local regulations.

5.2 PREPARATION

Pre-inspect the construction and service requirements for "Work by others." These requirements will be included in drawings, diagrams, engineering data sheets and special instructions before the work commences.

Part 6 - Warranty

The elevator contractor shall provide three (3) months free service from date of approval by local authorities. The entire elevator and all component parts shall carry a LIMITED WARRANTY for a period of two (2) Years. The warranty shall be for the replacement at no cost of defective parts but shall not include the labor costs required to replace the defective part or parts.

Part 7 – Owner's Instruction & Manual

After installation is completed, the contractor shall instruct the owner in the proper use, operation and maintenance requirements of the elevator. Instructions to also include emergency procedures, safety rules and precautions. Contractor shall also supply the owner with an Owner's Manual detailing the operating, safety, and maintenance procedures of the elevator.