

Planning Guide



SERENUS
LULA Elevator

This planning guide is designed to assist architects, contractors, home owners and elevator professionals in planning for a **SERENUS LULA Elevator** to meet the requirements of CAN/CSA B44.

We strongly recommend that you contact the code authority having jurisdiction in the area(s) where the elevator will be installed to become familiar with all the legal requirements governing the installation and use of elevators in private residences. It is extremely important for you to know and adhere to all regulations pertaining to the installation and use of elevators

This Planning Guide provides nominal dimensions and specifications useful for the initial planning of an elevator project. Before beginning actual construction make sure to receive application drawings customized with specifications and dimensions for your specific project.

DO NOT CONSTRUCT THE RETURN WALLS ON EITHER SIDE OR ABOVE ENTRANCES UNTIL AFTER WE HAVE ALIGNED THE DOORS AND FRAME ON SITE.

General Specifications

G1 The design and construction of all work is to conform to the local applicable building code.

G2 Read these drawings in conjunction with all related architectural, mechanical, electrical, and elevator drawings as well as any other contract documents.

G3 The wall drawings have been prepared using engineering principles and the design loads that are applied by the elevator rails to the wall. However, the details and member sizes and the

attachments to the structure should not be construed as a complete design of the wall system. The contractor and/or the project engineer is responsible to evaluate the other loads that are applied to the wall from the floor or roof system and modify member sizes or connections as required by their analysis.

The fused disconnect switch rating and fuse rating for the lift will be shown on the shop drawings forwarded for your project. **FOR ALL HYDRAULIC ELEVATORS WHERE EMERGENCY POWER IS SUPPLIED FROM A SECOND SOURCE FOR LOWERING THE CAR ONLY. THE DISCONNECTION MEANS SHALL BE PROVIDED WITH AN AUXILIARY CONTACT THAT IS POSITIVELY OPENED MECHANICALLY, (i.e. the opening not being solely dependent on springs), AND CONNECTED IN THE CONTROL CIRCUIT TO PREVENT MOVEMENT OF THE CAR WHEN THE DISCONNECTING MEANS IS OPEN.** Refer also to SECTION 38036 (3) OF THE **CSA STANDARD C221-1990, ELECTRICAL CODE.**

LOCKABLE FUSE DISCONNECT WITH AUXILIARY CONTACT AND A 110V DISCONNECT
When considering such items as tile flooring or other custom add-ons, care should be taken not to add more than 150 pounds to the overall weight of the lift.

Shop drawings take 1 -2 weeks after you place your order with us; the unit will be shipped 8-10 weeks.

We trust the above will be useful, but please contact us by phone or e-mail if you have any further questions.

LULA, CARELIFT, COMMERCIAL

PIT CONSTRUCTION

NOTES:

1. PIT TO BE LEVEL, DRY AND FREE OF DEBRIS
2. PIT LOAD: 3800 LBS OR 17KN (DOUBLED FOR IMPACT)
3. PIT MUST BE THE SAME WIDTH AND LENGTH AS THE HOISTWAY

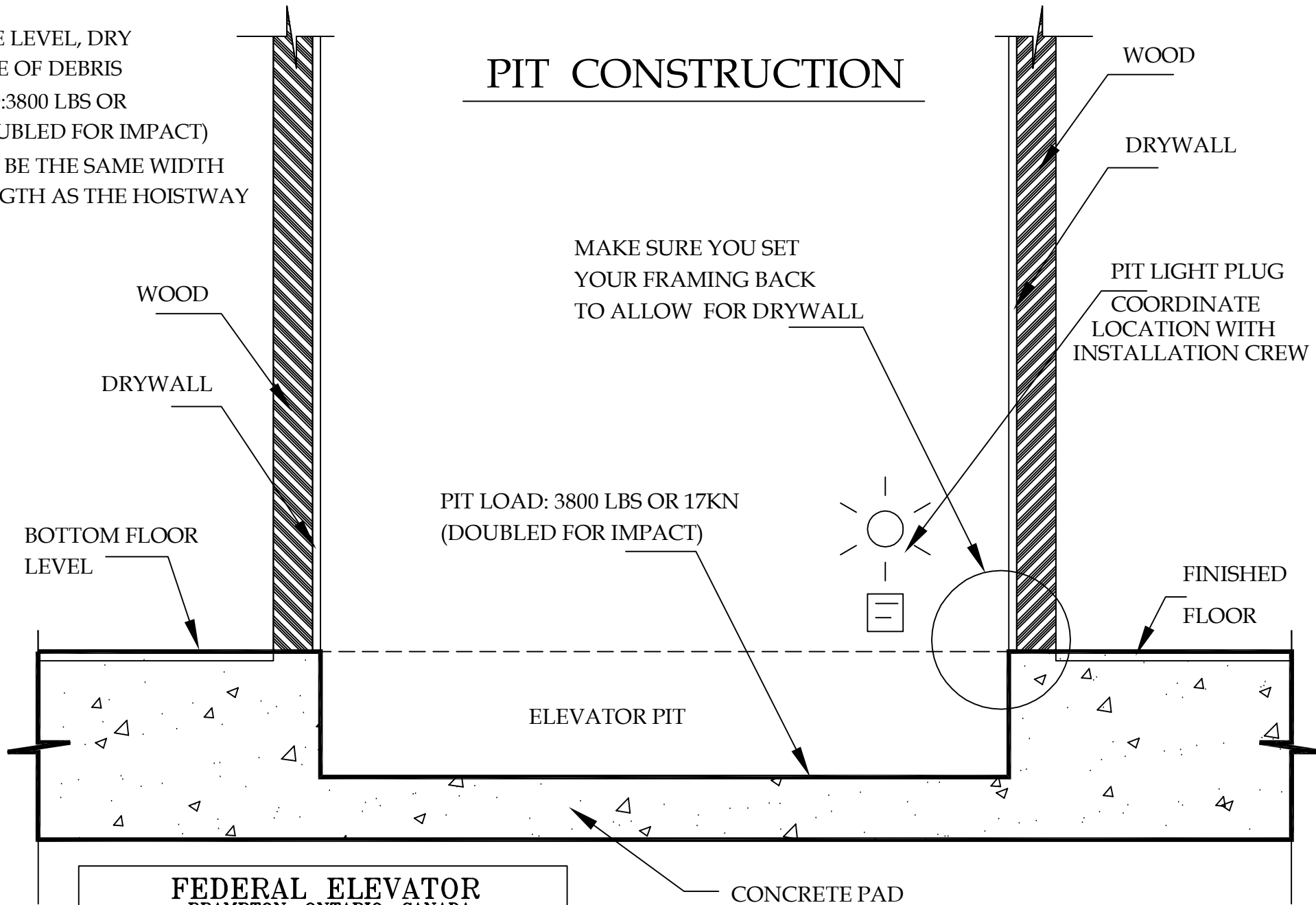

FEDERAL ELEVATOR
BRAMPTON, ONTARIO, CANADA
WEBSITE: www.federalev.com
Tel: (905) 458-4015 Fax: (905) 458-0680

30" D.B.G. RAIL BRACKET

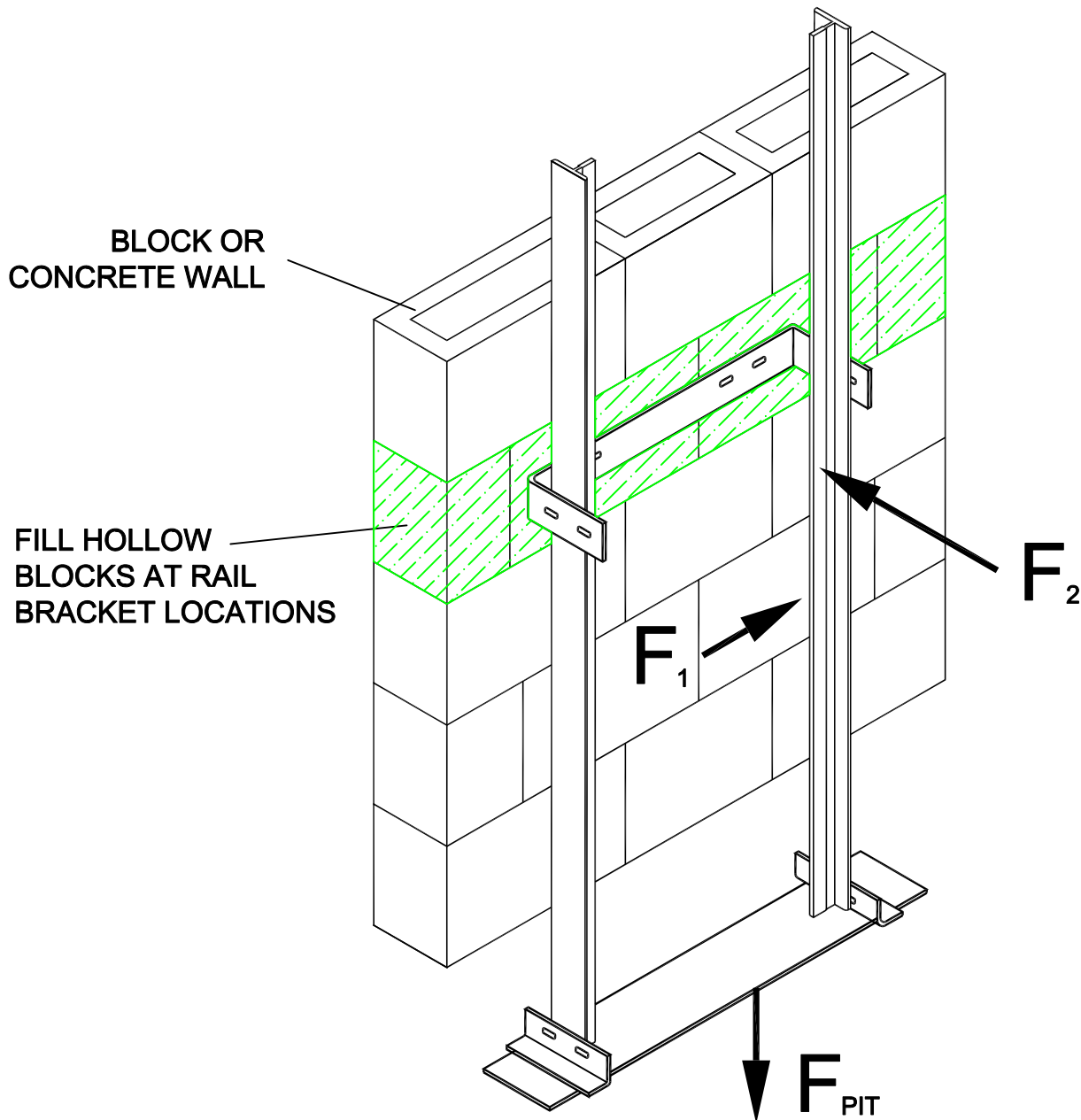
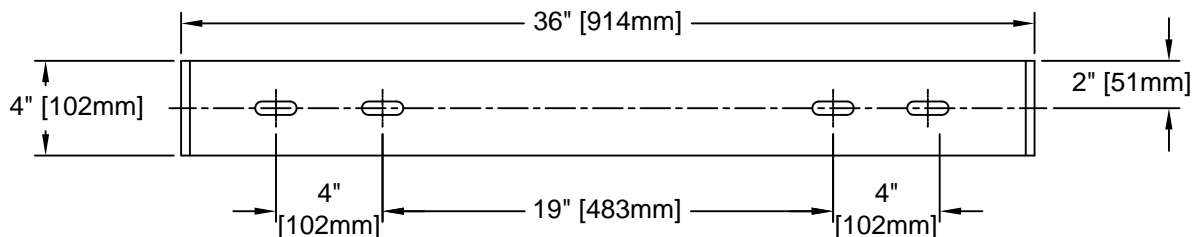

**FEDERAL
ELEVATOR**

43 WENTWORTH COURT
BRAMPTON, ONTARIO, CANADA L6T 5L4
TEL: (905) 458-4015
1 (888) 785-5438 (LIFT)
FAX: (905) 458-0680
www.federalelevator.com
E-MAIL: sales@federalelevator.com

LOAD

DESCRIPTION

LB_f [KN]

F_{PIT}

Load Imposed on Pit Floor
(Including Impact)

3825 [17.0]

F_1

Force on Rail

225 [1.0]

F_2

Force on Rail

675 [3.0]

27" D.B.G. RAIL BRACKET

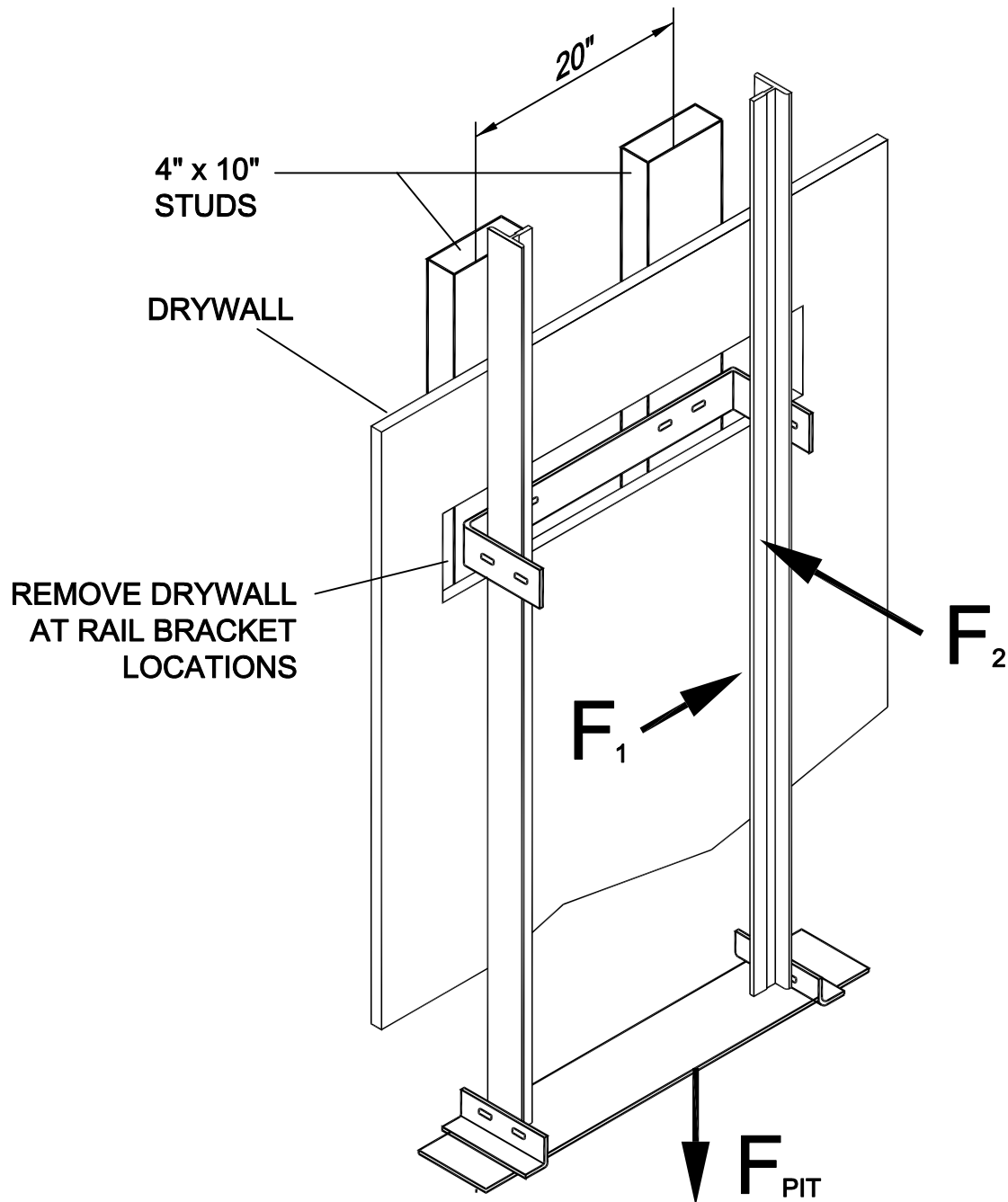
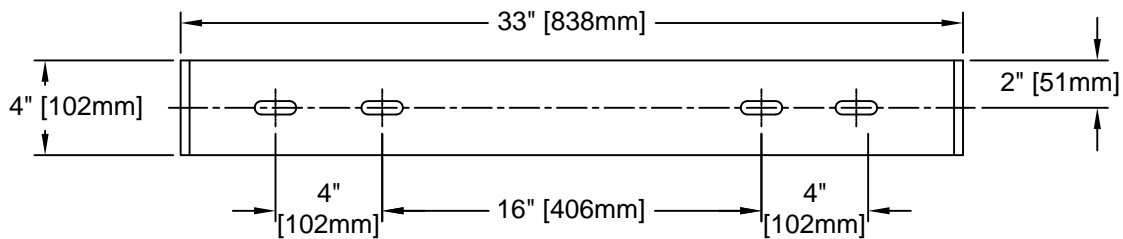

**FEDERAL
ELEVATOR**

43 WENTWORTH COURT
BRAMPTON, ONTARIO, CANADA L6T 5L4
TEL: (905) 458-4015
1 (888) 785-5438 (LIFT)
FAX: (905) 458-0680
www.federalelevator.com
E-MAIL: sales@federalelevator.com

LOAD

DESCRIPTION

LB_f [KN]

F_{PIT}

Load Imposed on Pit Floor
(Including Impact)

3825 [17.0]

F_1

Force on Rail

225 [1.0]

F_2

Force on Rail

675 [3.0]

RAIL BRACKET DETAIL ROPED

DIMENSIONS SHOWN BELOW ARE CORRECT FOR INSTALLATION PURPOSES.

CRITICAL DIMENSIONS ARE:

- 1) WALL TO CENTRE OF CYL. = 5 1/2" (140)
- 2) WALL TO CENTRE OF RAIL = 5 1/2" (140)
- 3) WALL TO CAB = 10" (254)

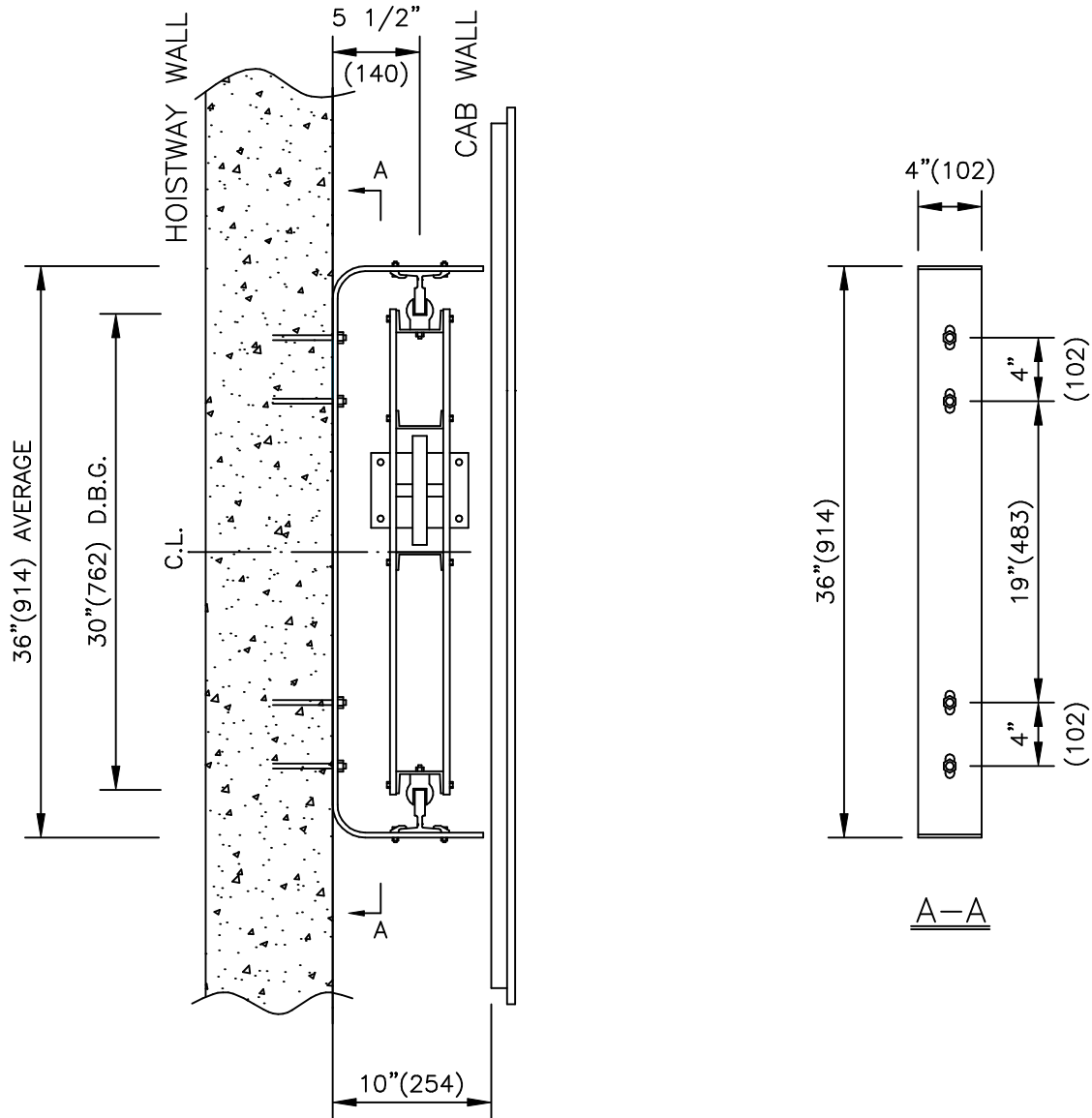

FEDERAL ELEVATOR SYSTEMS INC.
BRAMPTON, ONTARIO, CANADA

WEBSITE: www.federalelevator.com

PHONE: (905) 458-4015 FAX: (905) 458-0680

RAIL BRACKET DETAIL ROPED

DIMENSIONS SHOWN BELOW ARE CORRECT FOR INSTALLATION PURPOSES.

CRITICAL DIMENSIONS ARE:

- 1) WALL TO CENTRE OF CYL. = 5 1/2" (140)
- 2) WALL TO CENTRE OF RAIL = 5 1/2" (140)
- 3) WALL TO CAB = 10" (254)

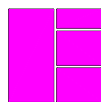
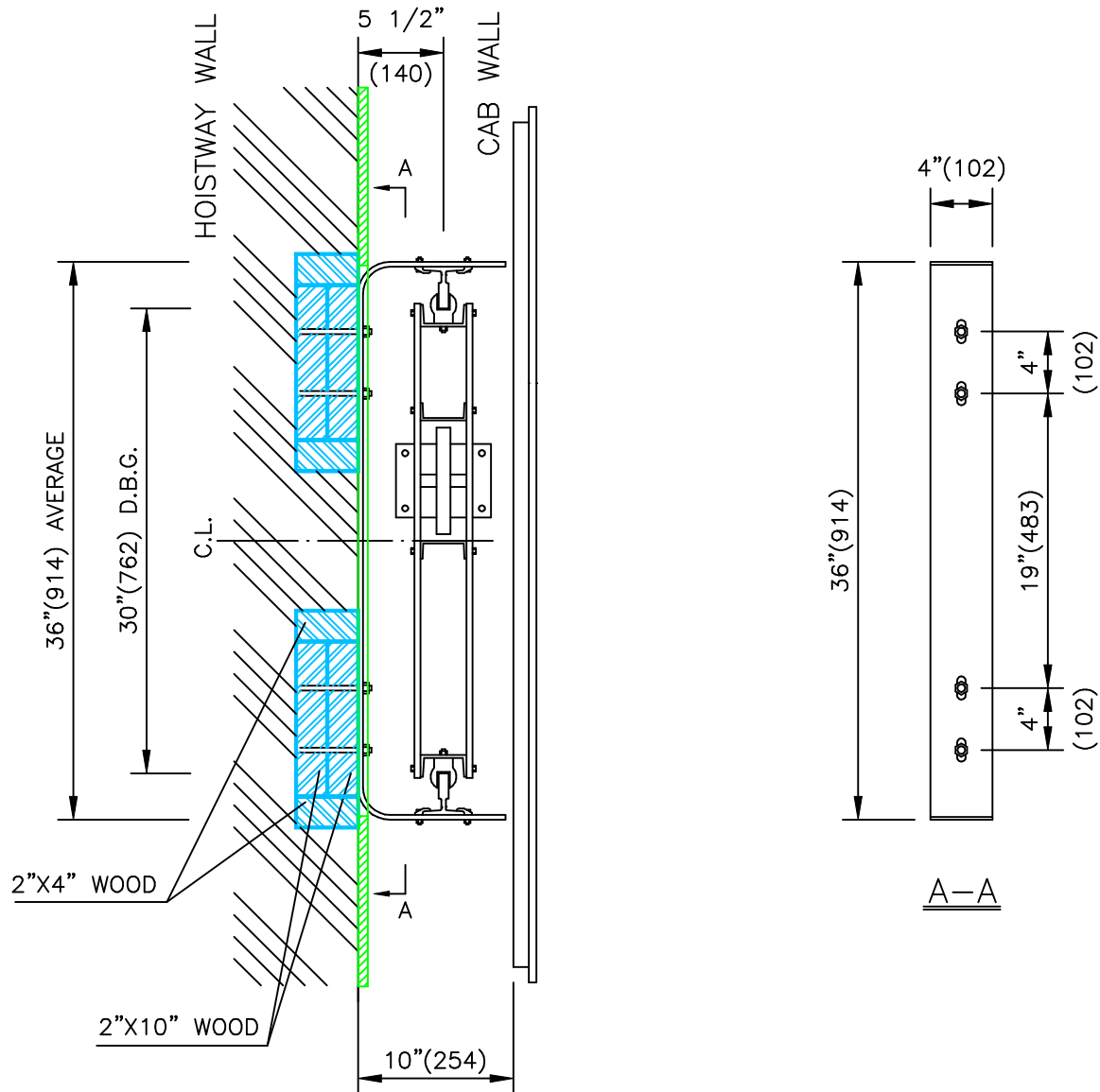

**FEDERAL
ELEVATOR**

FEDERAL ELEVATOR SYSTEMS INC.
BRAMPTON, ONTARIO, CANADA

WEBSITE: www.federalelevator.com

PHONE: (905) 458-4015 FAX: (905) 458-0680

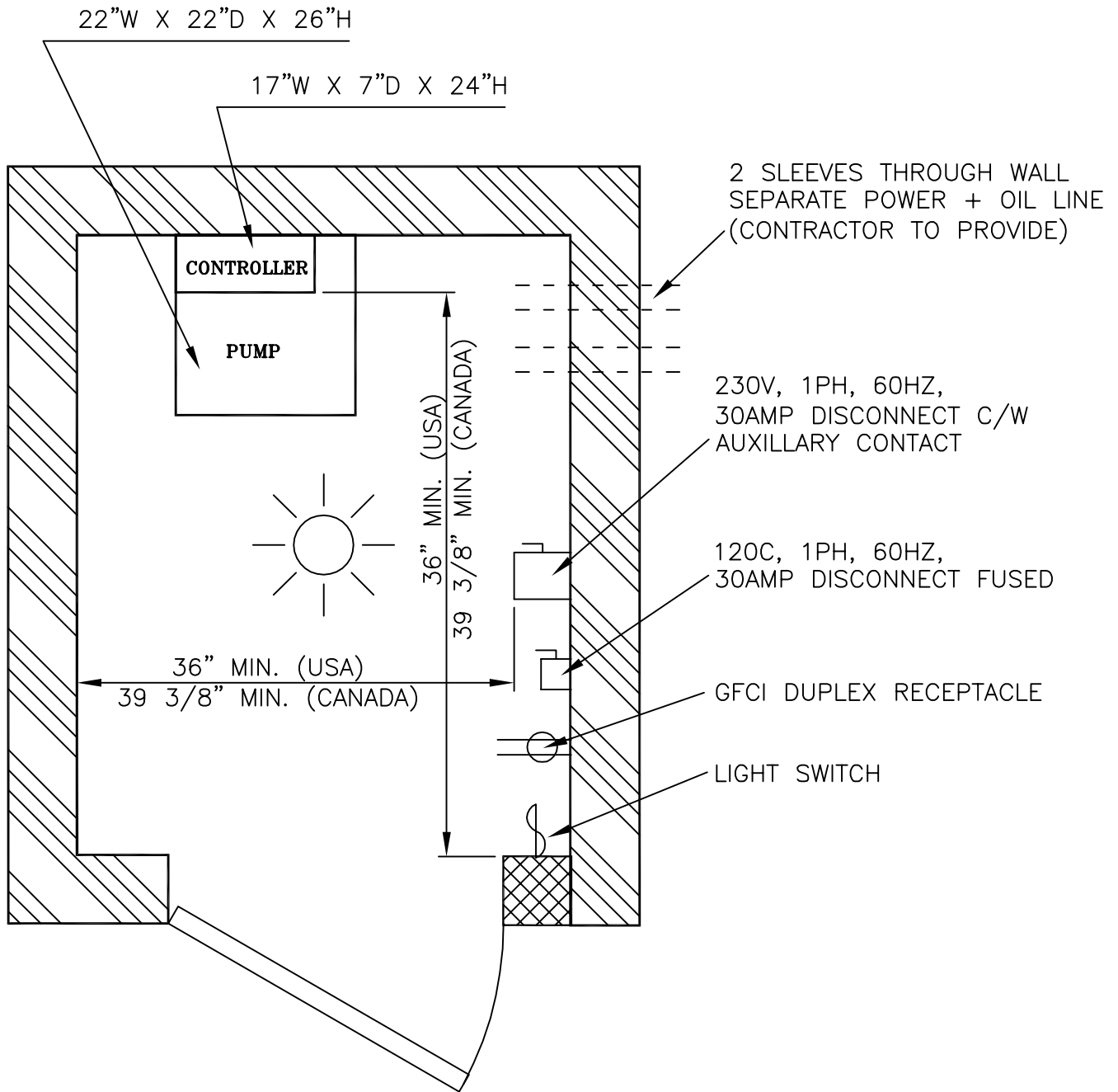

FEDERAL
ELEVATOR
Advanced Elevator Systems

43 Wentworth Court
Brampton, Ontario
Canada, L6T 5L4
Tel.: (905) 458-4015
1 (888) 785-5438 (LIFT)
Fax: (905) 458-0680
www.FederalElevator.com

ENTRANCE MOUNTING DETAILS FOR 2 SPEED DOORS WITH MASONRY CONSTRUCTION

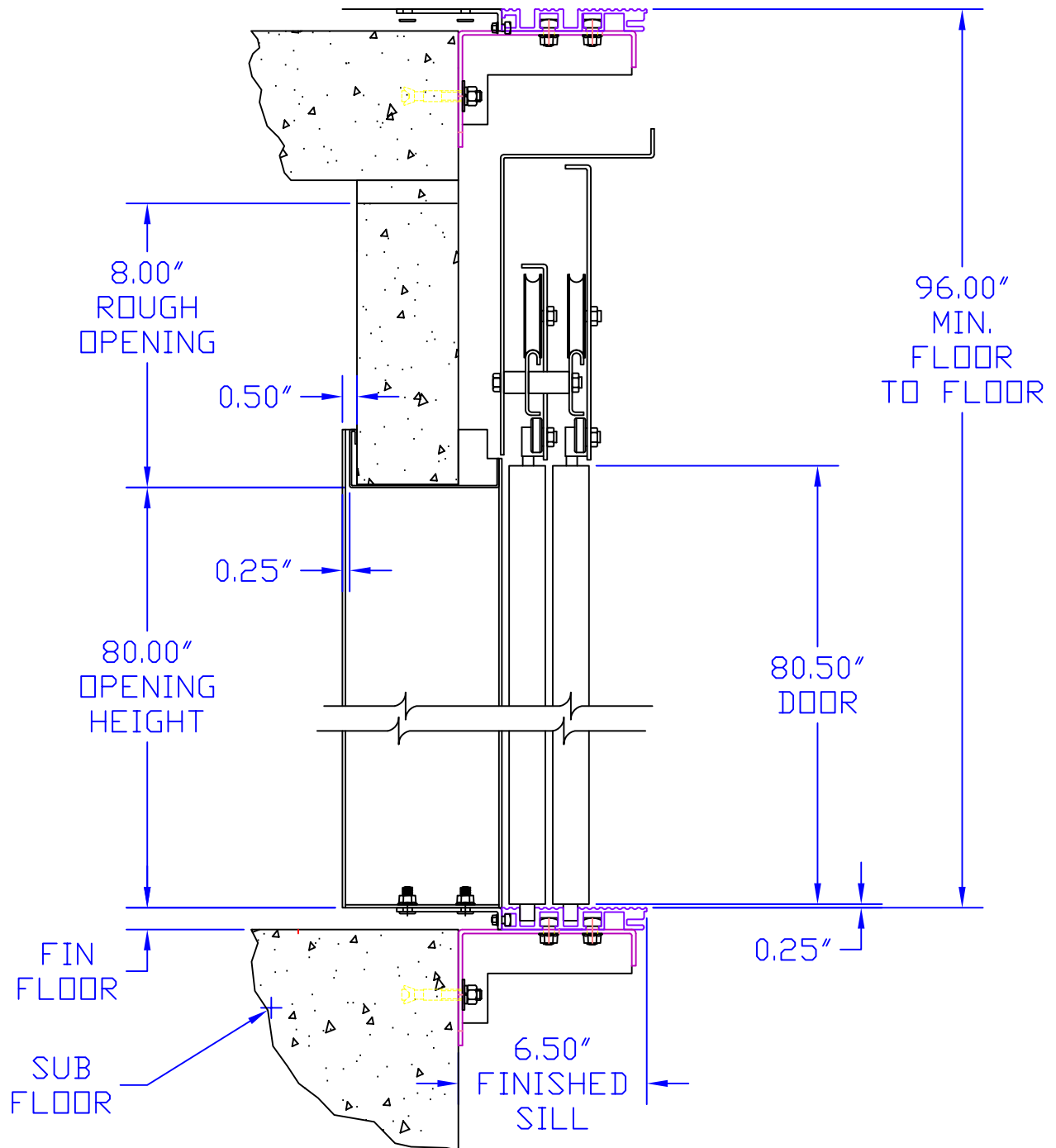

TYPICAL SECTION
(SILL ASSEMBLY FOR CONCRETE)

ENTRANCE MOUNTING DETAILS FOR 2 SPEED DOORS WITH MASONRY CONSTRUCTION

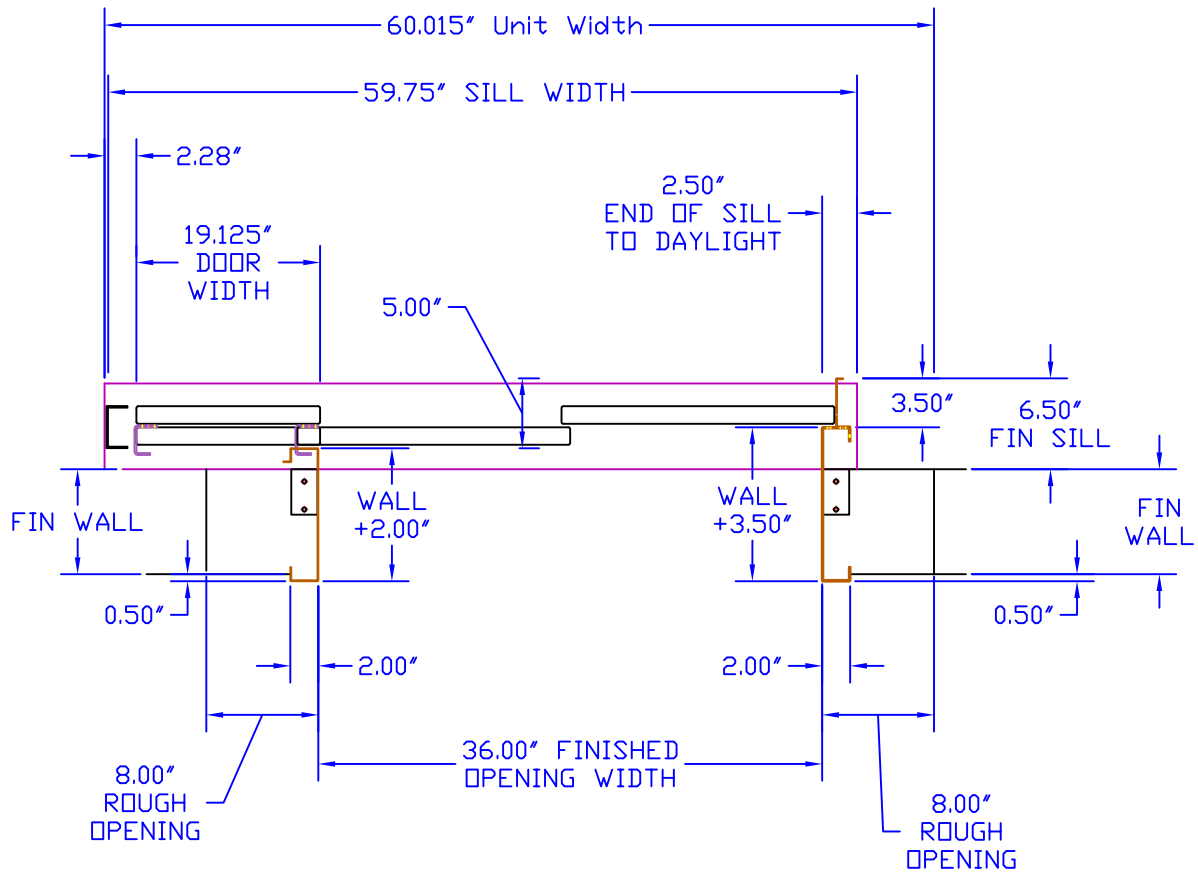

PLAN VIEW AT ENTRANCE
 (RIGHT HAND ENTRANCE SHOWN)

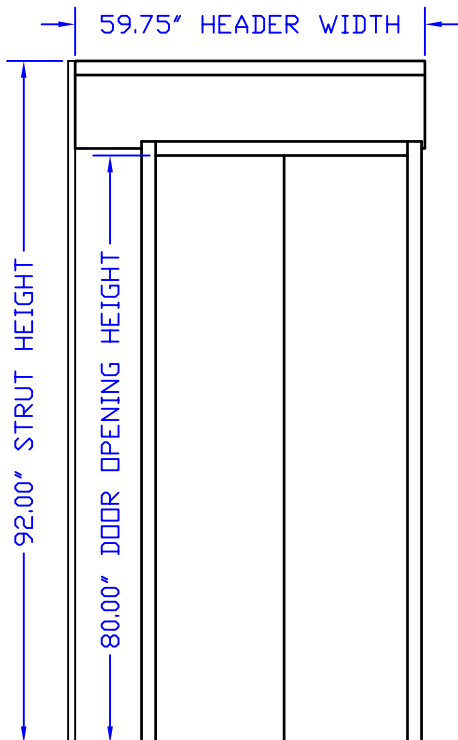

CORRIDOR ELEVATION

CONTRACTOR NOTE:

**DO NOT CONSTRUCT
 FRONT WALLS UNTIL
 DOOR FRAMES ARE SET
 - OR - LEAVE ROUGH
 OPENINGS AS SHOWN**



**43 WENTWORTH COURT
 BRAMPTON, ONTARIO, CANADA L6T 5L4
 TEL: (905) 458-4015
 1 888 785-5438 (LIFT)
 FAX: (905) 458-0680
 www.federalelevator.com
 E-MAIL: sales@federalelevator.com**

ENTRANCE MOUNTING DETAILS FOR 2 SPEED DOORS WITH DRYWALL CONSTRUCTION

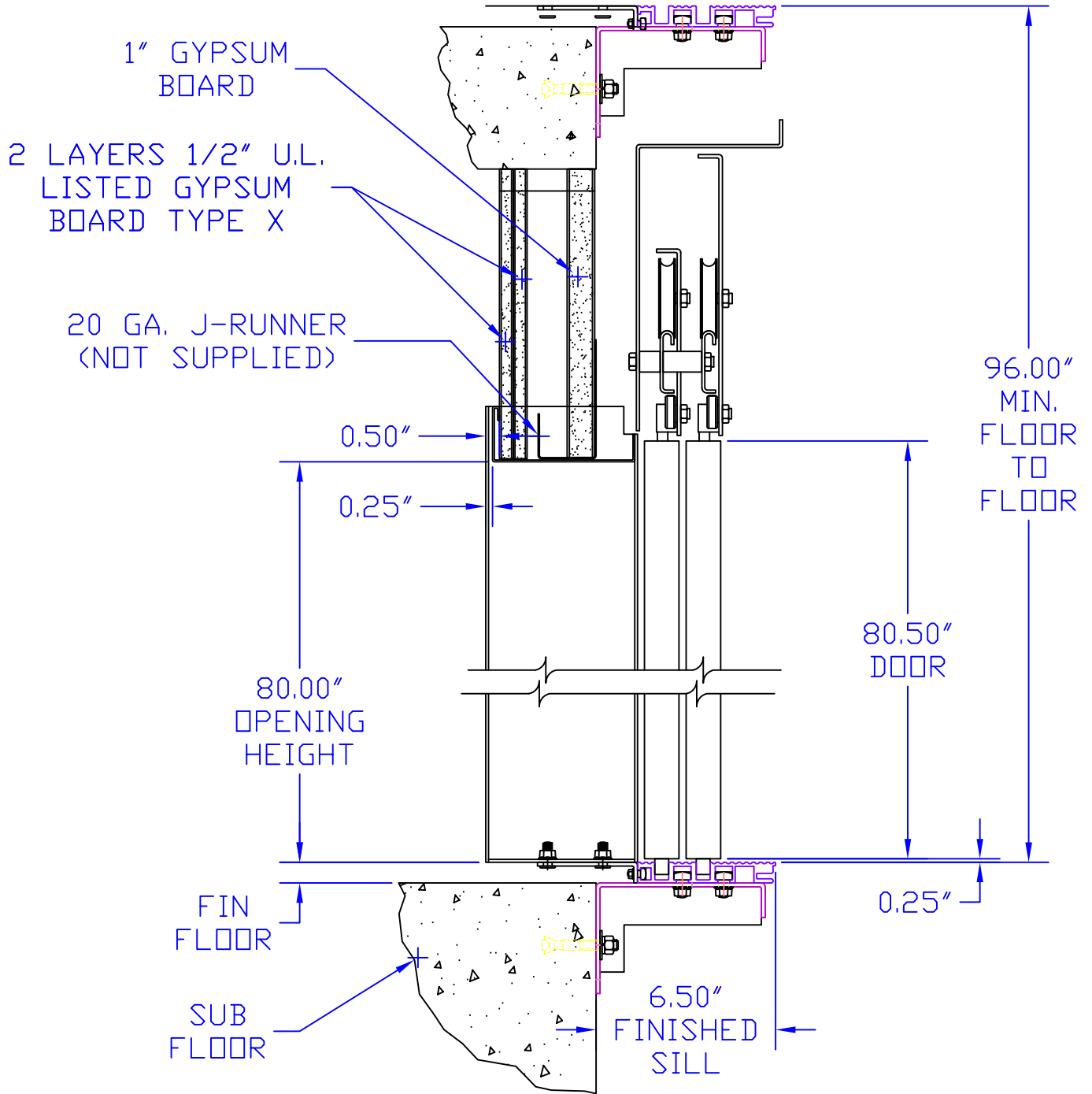

TYPICAL SECTION
(SILL ASSEMBLY FOR DRYWALL)

ENTRANCE MOUNTING DETAILS FOR 2 SPEED DOORS WITH DRYWALL CONSTRUCTION

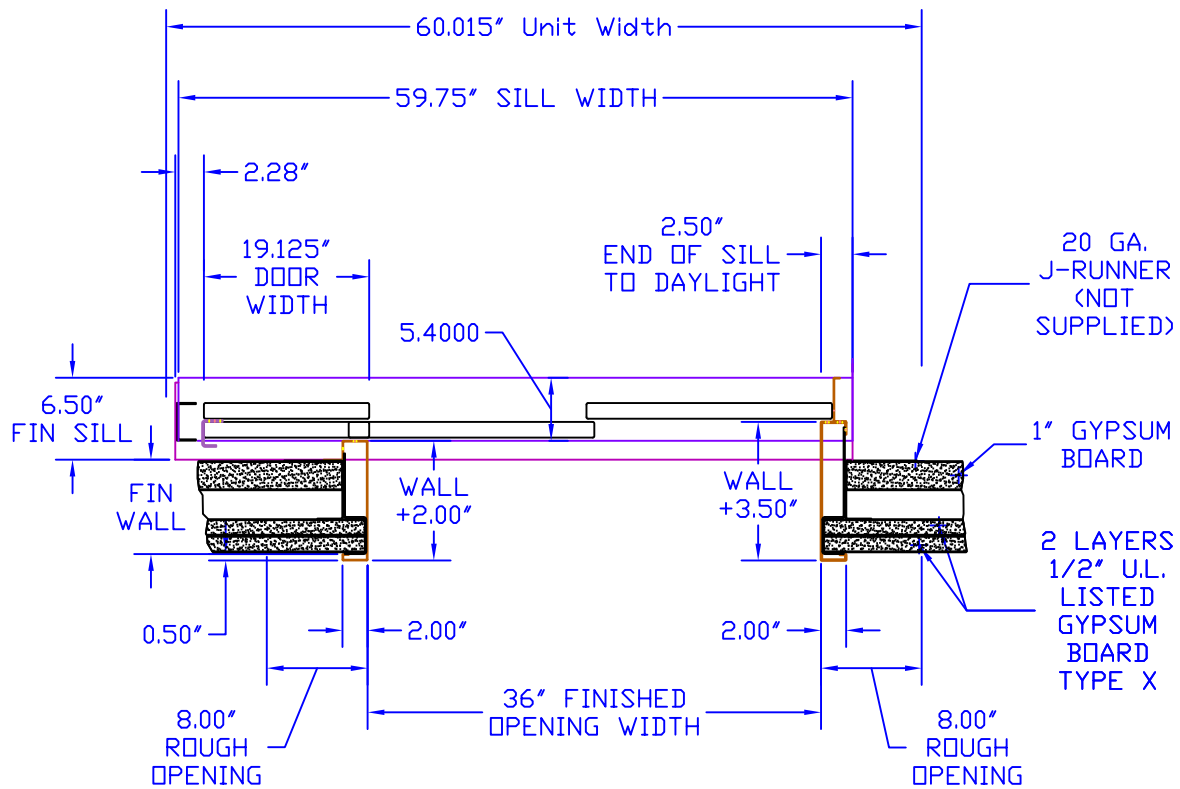

PLAN VIEW AT ENTRANCE
 (RIGHT HAND ENTRANCE SHOWN)

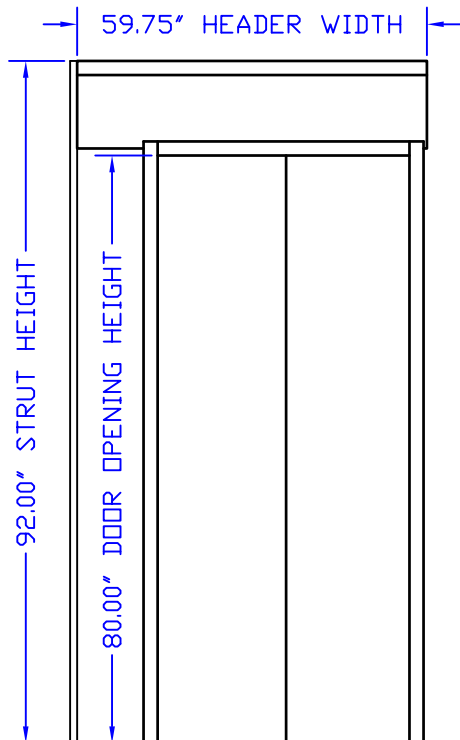

CORRIDOR ELEVATION

CONTRACTOR NOTE:

**DO NOT CONSTRUCT
 FRONT WALLS UNTIL
 DOOR FRAMES ARE SET
 - OR - LEAVE ROUGH
 OPENINGS AS SHOWN**



**43 WENTWORTH COURT
 BRAMPTON, ONTARIO, CANADA L6T 5L4
 TEL: (905) 458-4015
 1 888 785-5438 (LIFT)
 FAX: (905) 458-0680
 www.federalelevator.com
 E-MAIL: sales@federalelevator.com**

Part 4- Product Data

4.1 MANUFACTURER/ PRODUCT

Elevator shall be the FEDERAL SERENUS Commercial LU/LA Elevator manufactured by Federal Elevator Systems Inc. Toll Free Number (888) 785-5438 and (905) 458-4015, Fax (905) 458-0680

Rated Load: 1,400 lbs. (635 kg.)

Rated Speed: 30 fpm (0.15 m/s)

Car Dimensions: 48" W x 54" L Depth (1220 mm x 1372 mm)

Operation: Single Automatic Push Button

Power Supply: 220-Volt, Single Phase, 30 Amp or 208-Volt, 3 Phase, 60Amp.

Travel Distance: _____, Ft (Maximum as per local code)

Levels Served: _____, Maximum 4

Number of Openings: Maximum 2

Lighting Supply: 110-Volt, Single Phase, 60 cycle, 15 amps

Door Opening: 36" x 6' 8" (890 x 2030 mm) Nominal

Jack Type: 1:2 cable hydraulic

Pump Type: Submersible with Variable Speed Valve

Hoistway Door/Cab Door: 2-Speed Horizontal Sliding Hoistway Door with 2-Speed Horizontal Sliding Cab Door

Car Controller Type: Non-Propriety Programmable Logic Control (PLC)

Leveling Device Type: Magnetic Sensor

4.2 SIGNAGE

4.2.1

The elevator shall have all necessary signs, capacity plates, and data signs as per the local and national Codes and Standards.

4.12 SAFETY DEVICE

A "slack/broken cable" safety device shall be supplied, which will stop and sustain the elevator and its rated load, if either of the hoisting cables becomes slack or breaks. The safety device shall be resettable by the operation of the elevator in the upward direction. A switch shall be mounted in such a position to sense the operation of the safety device, and will open the safety circuit to the controller to prevent operation of the elevator in either direction.

Provide pit ladder for pits 3'-0" (914 mm) or more in depth.

2.1.12

Provide finish grouting and masonry around doorframes.

2.1.13

Provide finish painting of landing entrances.

Preparatory Work by Others

2.1

The following preparatory work to accommodate/receive the elevator is to be done by others:

2.1.1

Power unit machine room to meet applicable codes and standards.

2.1.2

Permanent power to operate the elevator to be provided to a lockable fused/cartridge type disconnect switch with auxiliary contact/switch for emergency battery lowering. Provide 110-volt lighting supply and disconnect. Refer to architectural drawings for permanent power specifications and location of the disconnects.

2.1.3

Provide appropriate sleeves for both the electrical conduit and hydraulic line from the power unit enclosure to the hoistway (as shown on drawings). Trenching may be required if the machine room is not adjacent to hoistway.

2.1.4

Provide machine room light and light switch, located to comply with applicable codes and standards.

2.1.5

Provide an enclosed, plumb and square hoistway with smooth interior surfaces. Include for fascias or furring of hoistway interior where applicable.

2.1.6

Suitable lintels over landing entrances are to be provided and provide rough openings as per elevator contractors' shop drawings.

2.1.7

Provide substantially level pit floor slab to support loads indicated on the elevator contractors' shop drawings.

2.1.8

Provide adequate support for guide rail fastenings.

2.1.9

Provide light, receptacle and switch in the pit, located to comply with applicable code.

2.1.10

Provide pit water proofing or sump pump, if required, as allowed by code.

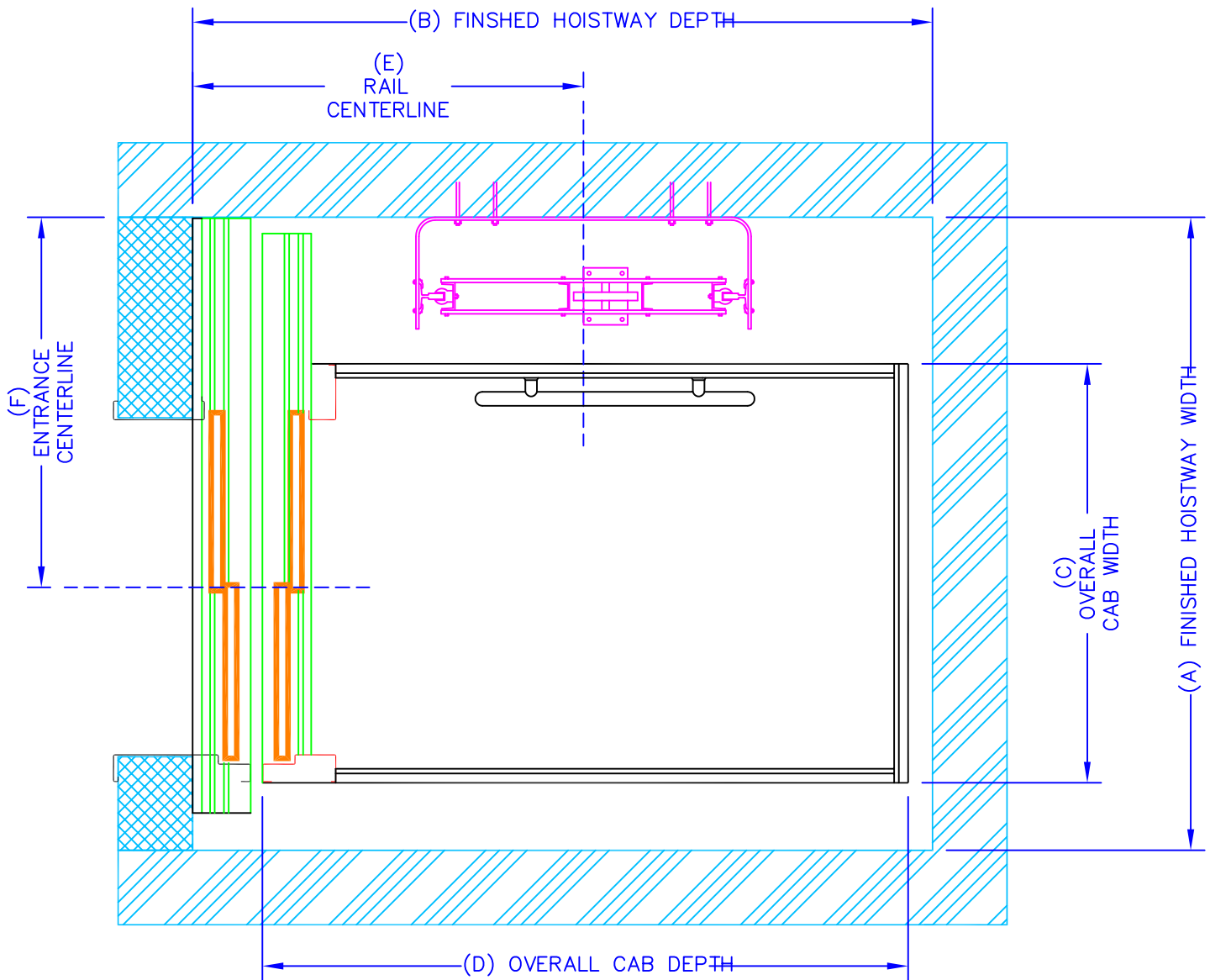

SERENUS TYPE A LEFT 2 SPEED DOOR

CAB SIZE	A	B	C	D	E	F
** 36"x60" (915x1525)	57" (1450)	82" (2085)	40" (1015)	70 1/4" (1785)	44 3/8" (1125)	33 1/2" (850)
42"x60" (1065x1525)	68" (1730)	79 1/2" (2020)	45" (1140)	69 3/8" (1760)	42" (1065)	39 3/4" (1010)
48"x54" (1220x1375)	68" (1730)	74 1/2" (1895)	51" (1295)	64 3/8" (1635)	42" (1065)	40 3/4" (1035)

**** REQUIRES THREE SPEED DOOR**



43 WENTWORTH COURT
BRAMPTON, ONTARIO, CANADA L6T 5L4
TEL: (905) 458-4015
1 888 785-5438 (LIFT)
FAX: (905) 458-0680
www.federalelevator.com
E-MAIL: sales@federalelevator.com

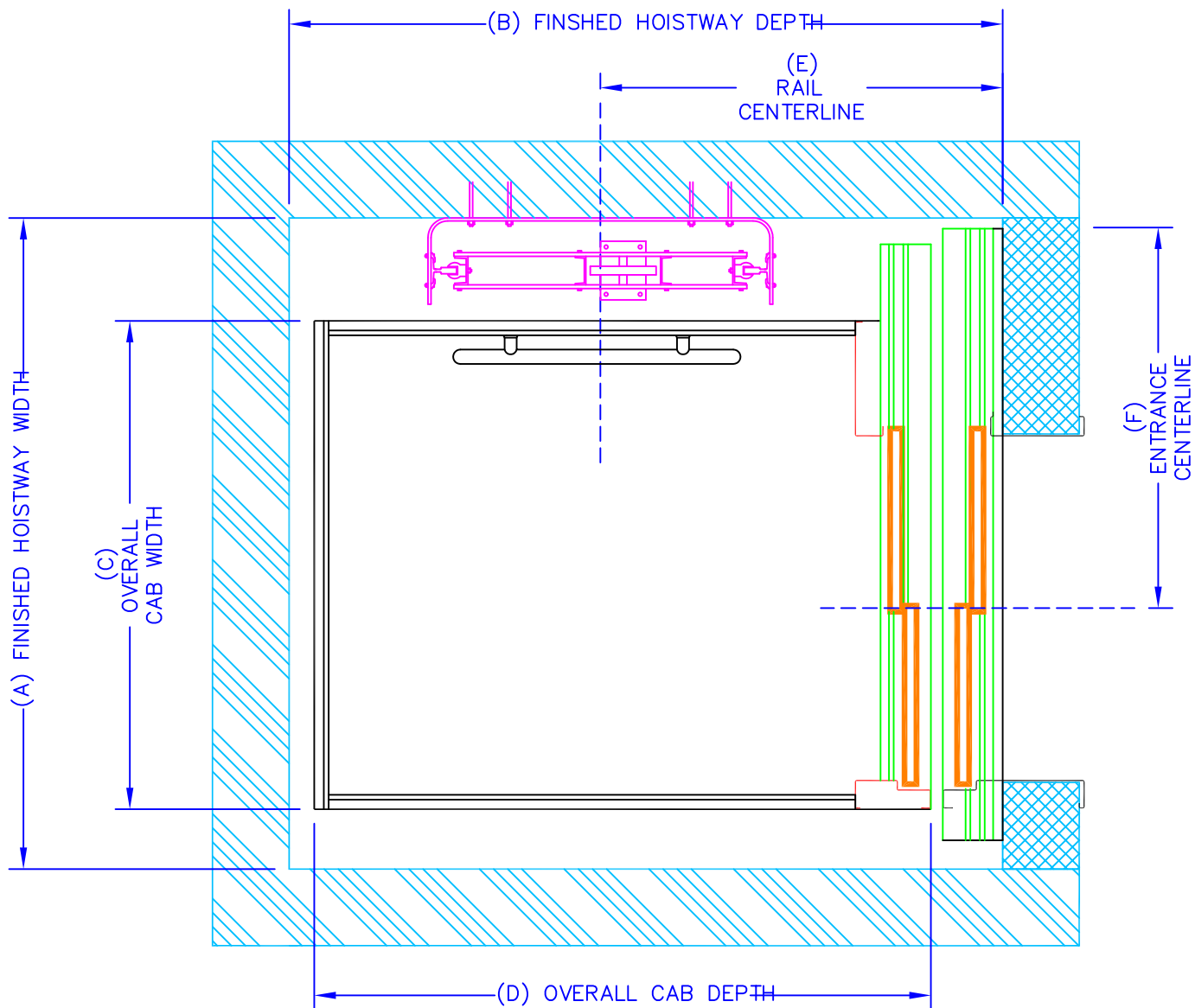

SERENUS TYPE A RIGHT 2 SPEED DOOR

CAB SIZE	A	B	C	D	E	F
** 36"x60" (915x1525)	57" (1450)	82" (2085)	40" (1015)	70 1/4" (1785)	44 3/8" (1125)	33 1/2" (850)
42"x60" (1065x1525)	68" (1730)	79 1/2" (2020)	45" (1140)	69 3/8" (1760)	42" (1065)	39 3/4" (1010)
48"x54" (1220x1375)	68" (1730)	74 1/2" (1895)	51" (1295)	64 3/8" (1635)	42" (1065)	40 3/4" (1035)

**** REQUIRES THREE SPEED DOOR**



43 WENTWORTH COURT
BRAMPTON, ONTARIO, CANADA L6T 5L4
TEL: (905) 458-4015
1 888 785-5438 (LIFT)
FAX: (905) 458-0680
www.federalelevator.com
E-MAIL: sales@federalelevator.com

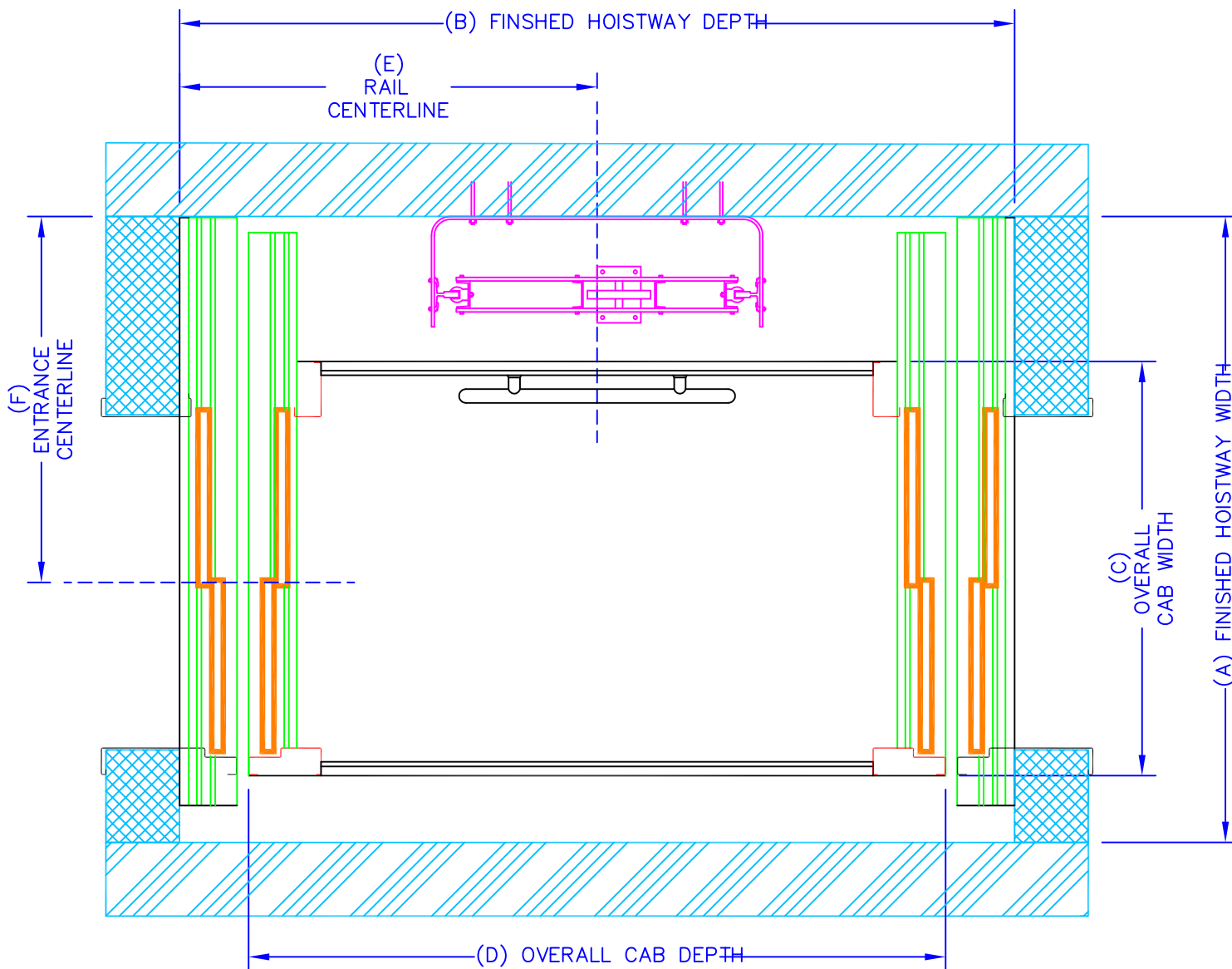

SERENUS TYPE B 2 SPEED DOOR

CAB SIZE	A	B	C	D	E	F
** 36"x60" (915x1525)	57" (1450)	96" (2440)	40" (1015)	77 1/2" (1970)	48" (1220)	33 1/2" (850)
42"x60" (1065x1525)	68" (1730)	90 3/4" (2305)	45" (1140)	75 3/4" (1925)	45 3/8" (1155)	39 3/4" (1010)
48"x54" (1220x1375)	68" (1730)	84 3/4" (2155)	51" (1295)	69 3/4" (1770)	42 3/8" (1075)	40 3/4" (1035)

**** REQUIRES THREE SPEED DOORS**



43 WENTWORTH COURT
BRAMPTON, ONTARIO, CANADA L6T 5L4
TEL: (905) 458-4015
1 888 785-5438 (LIFT)
FAX: (905) 458-0680
www.federalelevator.com
E-MAIL: sales@federalelevator.com

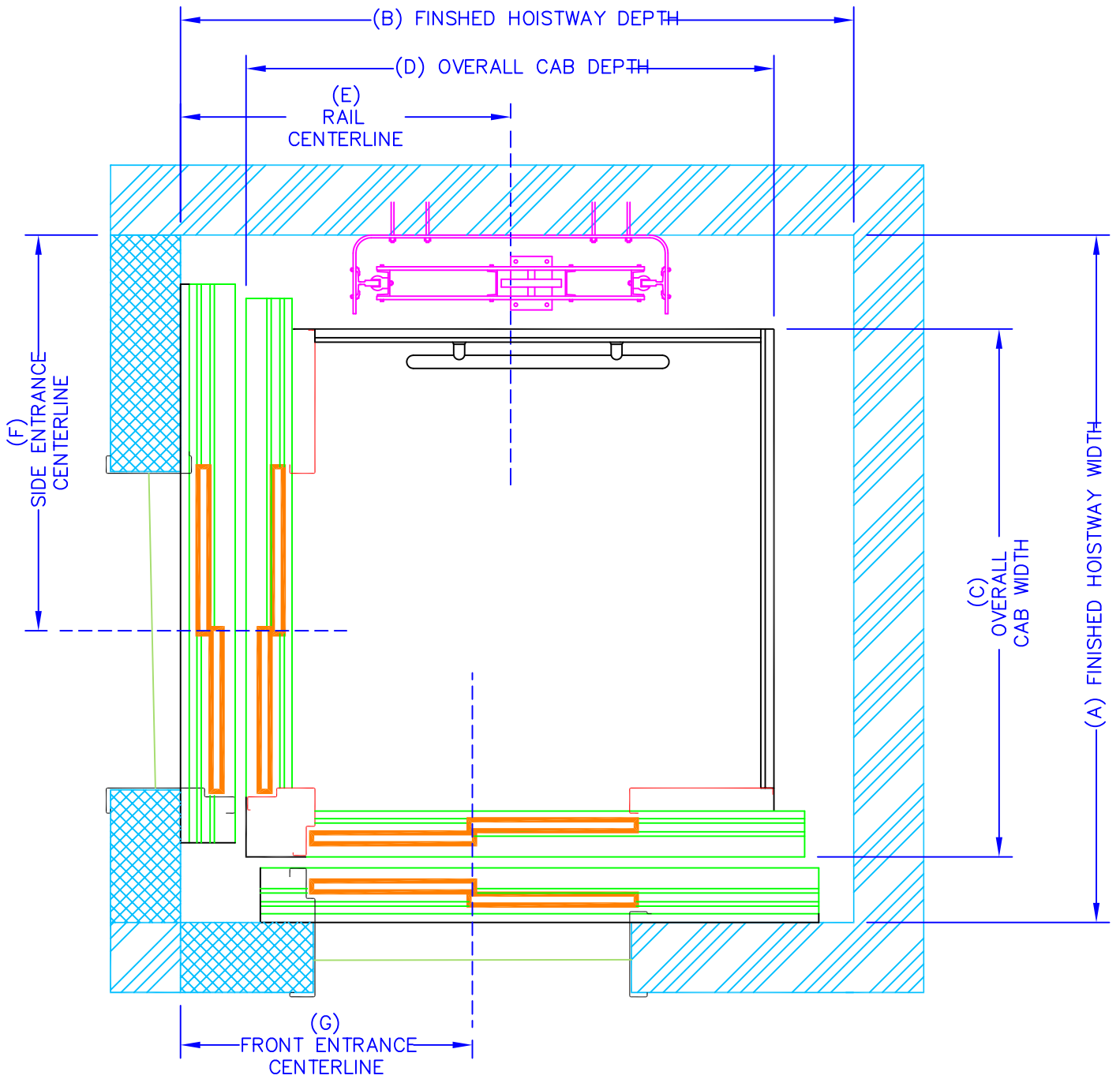

SERENUS TYPE D 2 SPEED DOOR

CAB SIZE	A	B	C	D	E	F	G
51"x51" (1295x1295)	78 5/8" (2000)	77" (1955)	60 3/8" (1535)	60 3/8" (1535)	37 3/4" (960)	45 1/4" (1150)	33 3/8" (850)



43 WENTWORTH COURT
BRAMPTON, ONTARIO, CANADA L6T 5L4
TEL: (905) 458-4015
1 888 785-5438 (LIFT)
FAX: (905) 458-0680
www.federalelevator.com
E-MAIL: sales@federalelevator.com

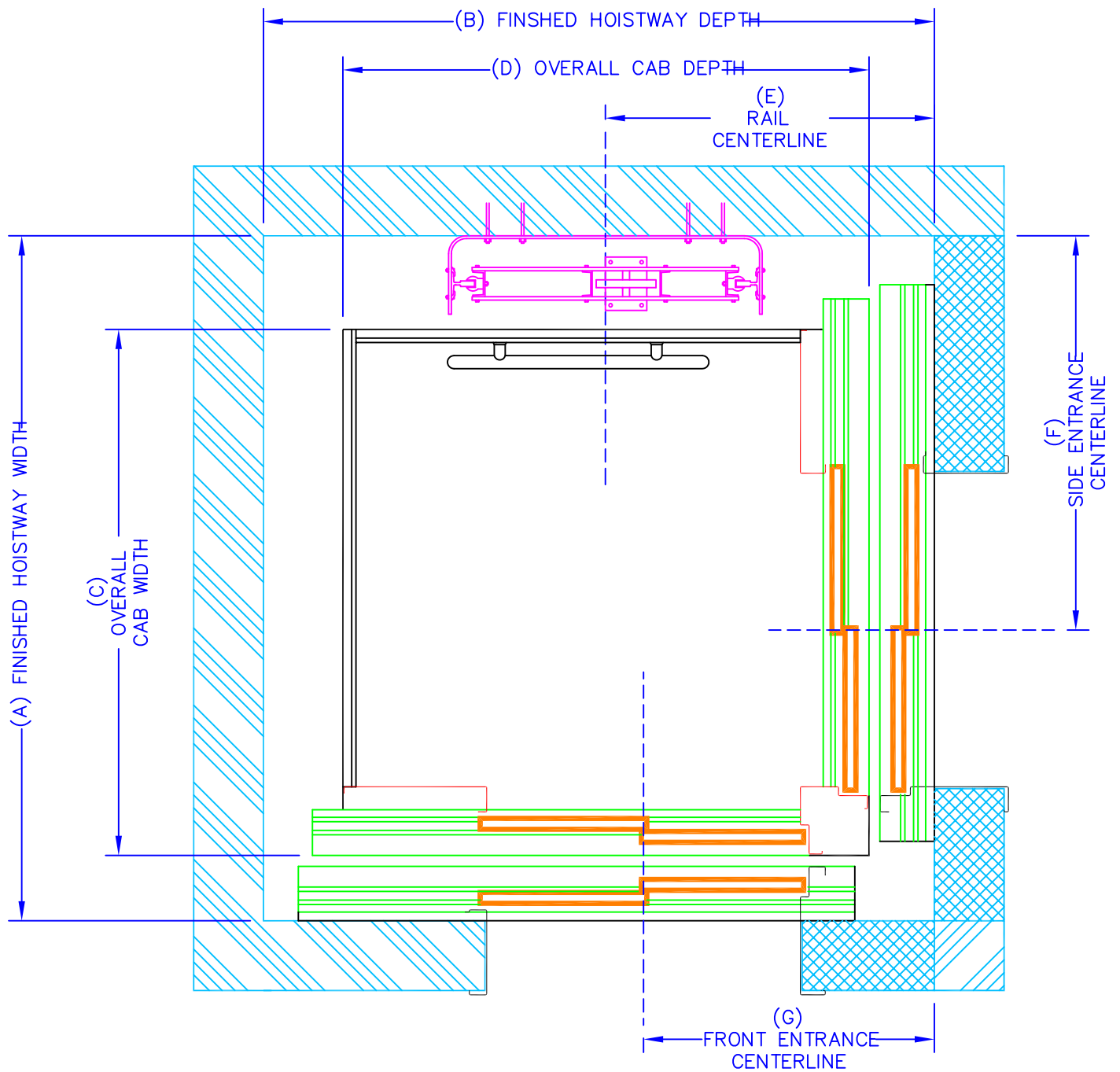

SERENUS TYPE C 2 SPEED DOOR

CAB SIZE	A	B	C	D	E	F	G
51"x51" (1295x1295)	78 5/8" (2000)	77" (1955)	60 3/8" (1535)	60 3/8" (1535)	37 3/4" (960)	45 1/4" (1150)	33 3/8" (850)



43 WENTWORTH COURT
BRAMPTON, ONTARIO, CANADA L6T 5L4
TEL: (905) 458-4015
1 888 785-5438 (LIFT)
FAX: (905) 458-0680
www.federalelevator.com
E-MAIL: sales@federalelevator.com

Part 1- General

1.1 SCOPE

To furnish all labor, materials and equipment necessary or required to fully complete the installation of the elevator as shown on the drawings and specifications. This suggested specification is intended to cover the complete installation of the Federal Serenus Commercial LU/LA Elevator design.

1.2 SYSTEM DESCRIPTION

The elevator assembly shall consist of a power unit, car, rail guide system, 1:2 cable hydraulic lifting device, hoistway doors, car doors, control system, signals and alarms, electrical wiring, and parts and accessories necessary to provide required performance, operation, code and safety requirements.

1.3 QUALITY ASSURANCE

1.3.1

The elevator shall meet or exceed the applicable regulations of all governing agencies and be in compliance with the applicable sections of the most current edition of the following codes and standards:

- a) ASME A17.1 "Safety Code for Elevators and Escalators, Section 5.2 Limited Use/Limited Application Elevators".
- b) CSA B44-07 "Safety Code for Elevators, Section 5.2 Limited Use/Limited Application Elevators"
- c) ICC/ANSI A117.1-1998 "Accessible and Usable Buildings and Facilities".
- d) ANSI/NFPA 70-1999 "The National Electric Code" (NEC).
- e) ADAAG "Americans with Disabilities Act Accessibility Guidelines" (where applicable).
- f) CSA B44.1/ASME A17.5 "Elevator and Escalator Electrical Equipment".
- g) Local codes and regulations, as applicable.

1.3.2

Requirements of the Regulatory Agencies:

- a) Fabricate and install Work in compliance with all applicable jurisdictional authorities.
- b) File shop drawings and submissions to local authorities as the information is made available. Company pre-inspection and jurisdictional authority inspections and permits are to be made on a timely basis as required. Work will include all inspections and re-inspections that are required to ensure licenses are issued.

Subcontractor Qualifications:

- a) Execute work of this specification only by a contractor/company who has adequate product and public liability insurance in excess of five million dollars.
- b) Skilled tradesmen must be employees of the contractor to perform the work on a timely basis. Employees must be trained by the manufacturer and be supervised by the elevator contractor.

1.3.4

Substitutions:

No substitutions will be considered unless written request for approval has been submitted by the bidder and received by the architect at least 10 days before the date of receipt of bids. Each such request shall include a complete description of the proposed substitute including drawings, test data, photographs, and any other information needed for consideration.

Part 2 - Preparatory Work by Others

2.1

The following preparatory work to accommodate/receive the elevator is to be done by others:

2.1.1

Power unit machine room to meet applicable codes and standards.

2.1.2

Permanent power to operate the elevator to be provided to a lockable fused/cartridge type disconnect switch with auxiliary contact/switch for emergency battery lowering. Provide 110-volt lighting supply and disconnect. Refer to architectural drawings for permanent power specifications and location of the disconnects.

2.1.3

Provide appropriate sleeves for both the electrical conduit and hydraulic line from the power unit enclosure to the hoistway (as shown on drawings). Trenching may be required if the machine room is not adjacent to hoistway.

2.1.4

Provide machine room light and light switch, located to comply with applicable codes and standards.

2.1.5

Provide an enclosed, plumb and square hoistway with smooth interior surfaces. Include for fascias or furring of hoistway interior where applicable.

2.1.6

Suitable lintels over landing entrances are to be provided and provide rough openings as per elevator contractors' shop drawings.

2.1.7

Provide substantially level pit floor slab to support loads indicated on the elevator contractors' shop drawings.

2.1.8

Provide adequate support for guide rail fastenings.

2.1.9

Provide light, receptacle and switch in the pit, located to comply with applicable code.

2.1.10

Provide pit water proofing or sump pump, if required, as allowed by code.

2.1.11

Provide pit ladder for pits 3'-0" (914 mm) or more in depth.

2.1.12

Provide finish grouting and masonry around doorframes.

2.1.13

Provide finish painting of landing entrances.

Part 3- Submittals

3.1 Shop Drawings

The shop drawings shall show a complete layout of the elevator equipment detailing dimensions, clearances and location of machinery. Including, but not limited to, the following:

3.1.1

Drawings showing the dimensions including plans, elevations, and sections to show equipment locations.

3.1.2

Load and reaction drawings shall be provided by the elevator manufacturer and detailed on drawings.

3.2

SAMPLES

Part 4- Product Data

4.1 MANUFACTURER/ PRODUCT

Elevator shall be the FEDERAL SERENUS Commercial LU/LA Elevator manufactured by Federal Elevator Systems Inc. Toll Free Number (888) 785-5438 and (905) 458-4015, Fax (905) 458-0680

Rated Load: 1,400 lbs. (635 kg.)

Rated Speed: 30 fpm (0.15 m/s)

Car Dimensions: 48" W x 54" L Depth (1220 mm x 1372 mm)

Operation: Single Automatic Push Button

Power Supply: 220-Volt, Single Phase, 30 Amp or 208-Volt, 3 Phase, 60Amp.

Travel Distance: _____, Ft (Maximum as per local code)

Levels Served: _____, Maximum 4

Number of Openings: Maximum 2

Lighting Supply: 110-Volt, Single Phase, 60 cycle, 15 amps

Door Opening: 36" x 6' 8" (890 x 2030 mm) Nominal

Jack Type: 1:2 cable hydraulic

Pump Type: Submersible with Variable Speed Valve

Hoistway Door/Cab Door: 2-Speed Horizontal Sliding Hoistway Door with 2-Speed Horizontal Sliding Cab Door

Car Controller Type: Non-Propriety Programmable Logic Control (PLC)

Leveling Device Type: Magnetic Sensor

4.2 SIGNAGE

4.2.1

The elevator shall have all necessary signs, capacity plates, and data signs as per the local and national Codes and Standards.

4.2.2

A capacity plate indicating the rated load in pounds and kilograms and operating instructions shall be furnished by the manufacturer and fastened in a prominent place at each landing and in the cab. The capacity plate and operating instructions will be engraved on non-glare, micro-surface, white letters on a blue background, self-adhesive, flexible plastic material. The letters and figures stating the capacity shall not be less than 1/4" in height.

4.3 FULLY AUTOMATIC OPERATION

The operation shall be single automatic push button. Each landing shall be equipped with a single light up button/digital floor indicator and audible arrival chime. Upon momentary pressure of the landing or car button, the call shall register in the control system and remain in memory until answered.

4.4 CAR ENCLOSURE

4.4.1 WALLS

Steel cab with 3/4" (19 mm) clip-on fire rated laminated panels. Painted cab frame reveal to be Federal standard black or architectural white. Clip-on Panel selected from Concord's Standard plastic laminate selection.

4.4.2 CEILINGS

Non-removable Hi Gloss Architectural white painted baked enamel steel ceiling with 4 incandescent down lights

4.4.3 FLOOR

Steel frame and flooring with plywood sheeting.

4.4.4 HANDRAIL

One (1) stainless steel handrail shall be located on control wall of the cab.

4.4.5 EMERGENCY OPERATION

The car will be equipped with a battery powered emergency lowering and door opening device and alarm which is automatically actuated in the event of failure of the normal building power supply. Battery will be rechargeable with an automatic recharging system.

4.4.6 EMERGENCY LIGHTING

In the event of a main power supply failure, an integral, battery powered emergency light will provide cab lighting.

4.4.7 Tactile Plates

Provide metal tactile plates 1 1/4" X 1 1/4" on the cab control panel beside the appropriate button indicating the floor number and/or function. Also provide metal tactile plates 3" X 4" at each floor located on the doorjamb indicating the appropriate floor number.

4.4.8 CAR OPERATING PANEL

Car operating panel shall be hinged and shall consist of metal push button with halo lighting for each landing, emergency alarm, keyed stop switch, door open and close buttons all mounted on (#4 finished). Stainless steel panel. The car-operating panel will be engraved with Fireman Service instructions.

4.4.9 Car Travel Lanterns

Provide a visual indicator to indicate the direction of travel of the car and audio signal upon floor arrival, if required by local code.

4.4.10 DIGITAL FLOOR INDICATOR

A digital floor indicator located in the control panel will display the location (floor number) of the elevator in the shaft.

4.4.11 CAR LIGHTING

The car lighting shall consist of four- (4) low voltage incandescent down lights.

The failure of one lamp shall not cause the remaining lamps to extinguish.

4.4.12 AUTOMATIC LIGHTS

Overhead lights in the car compartment shall turn ON automatically when the elevator door is opened and stay ON while the elevator is in use. The elevator lights will shut OFF by a timer when the elevator is not in use.

4.5 PLATFORM TOE GUARD

A platform toe guard shall be provided at each car entrance opening to extend below car entrance opening for safety.

4.6 LEVELING DEVICE

4.6.1

The elevator shall be provided with a 2 way-leveling device, which will maintain the car within 1/2" (13 mm) of the landing, by magnetic sensor.

4.6.2

Leveling device switches shall be located in a position to be inaccessible to unauthorized persons.

4.6.3

Hoistway car position signals shall be magnetically sensed for quiet operation.

4.7 TWO SPEED HORIZONTAL SLIDING HOISTWAY DOOR/CAB GATE

4.7.1 Cab Door Operation

- a) Power operated, two speed horizontal sliding, zinc wipe coated, steel panels providing a clear opening of 36" x 80" (914 mm x 2032mm) shall be provided.
- b) Doors on the car and at the hoistway entrances shall be power operated by means of a solid-state 24 volt D.C. operator with smooth quiet belt drive transmission, operable during power failure.
- c) Door operation shall be automatic at each landing with door opening being initiated as the car arrives at the landing and closing taking place after expiration of an adjustable time interval.
- d) All control adjustments shall be potentiometer regulated.
- e) The door shall be equipped with an infrared self-contained light curtain that will stop and reverse the doors should it detect an obstacle.
- f) The car doors shall be equipped with a master door clutch to control the individual landing door electrical-mechanical interlocks.
- g) The car door electric contact shall prevent the elevator from moving away from the landing unless the car door is in the closed position and the controller will monitor the door contacts and register a fault if any have been bypassed
- h) The car doorsill shall be extruded aluminum.

4.7.2 Hoistway Doors

- a) Two speed horizontal sliding, zinc wipe coated, steel panels providing a clear opening of 36" (914 mm) x 80" (2032 mm) shall be provided at each landing.
- b) Frames shall be of bolted construction for a one-piece unit assembly comprised of head and side jamb sections.
- c) The door assembly shall be 1 1/2 UL/ULC labeled and provided with approved electrical mechanical interlocks.
- d) The landing doorsill shall be extruded aluminum with non-slip wearing surfaces and grooves for door guides.

4.8 HYDRAULIC POWER UNIT

- a) The pump and motor shall be the submersible type installed inside the oil tank.
- b) The controller shall be integrally mounted on the power unit frame.
- c) Control circuitry to be Programmable Logic Controls and be located on the pump unit.
- d) The power unit control valve shall be a variable speed proportional valve type that includes all hydraulic control valving inherently.

This valve shall incorporate the following features:

- (i) Up and down acceleration and deceleration speed adjustment for a smooth starts and stops.
- (ii) Smooth stops at each landing shall be an inherent feature of the valve.
- (iii) Adjustable pressure relief valve.
- (iv) Manually operating DOWN valve to lower elevator in an emergency.
- (v) Pressure gauge indicating in P.S.I. and Bars.
- (vi) Gate valve to isolate cylinder from pump unit.
- (vii) Negative pressure switch

4.9 NEGATIVE PRESSURE SWITCH

In addition to the standard operating features of the hydraulic control valve, there shall be a pressure sensitive check valve that will activate when negative pressure is sensed in the hydraulic system. The check valve will close and stop the hydraulic jack from descending immediately on sensing negative pressure.

4.10 CYLINDER AND PLUNGER

4.10.1

The cylinder shall be constructed of steel pipe of a sufficient thickness and suitable safety margin. The top of the cylinder shall be equipped with a cylinder head with an internal guide ring and self-adjusting packing.

4.10.2

The plunger shall be constructed of a steel shaft of a proper diameter machined true and smooth. The plunger shall be provided with a stop electrically welded to the bottom to prevent the plunger from leaving the cylinder.

4.11 CABLE

Minimum of two 3/8" (10 mm).

4.12 SAFETY DEVICE

A "slack/broken cable" safety device shall be supplied, which will stop and sustain the elevator and its rated load, if either of the hoisting cables becomes slack or breaks. The safety device shall be resettable by the operation of the elevator in the upward direction. A switch shall be mounted in such a position to sense the operation of the safety device, and will open the safety circuit to the controller to prevent operation of the elevator in either direction.

4.13 GUIDE YOKE

The 1:2 guide yoke/sheave arrangement shall be supplied with a sheave, guide shoes, roller bearings and adjustable cable guards. The sheave shall be finished with rounded grooves to fit the cables.

4.14 NORMAL TERMINAL STOPPING DEVICES

Normal terminal stopping devices shall be magnetically sensed at the top and bottom of runway to stop the car automatically.

4.15 GUIDE RAILS AND BRACKETS

4.15.1

Steel 8lb/ft" T" guide rails and brackets shall be securely fastened to the building structure.

4.15.2

Brackets shall securely hold the guides in a plumb and true position regardless of car loading.

4.15.3

Guides shall be bolted through the hoistway enclosure with "back-up" plates, washers and nuts. Subject to architects' alterations and approvals.

4.16 CAR SLING

4.16.1

Car sling shall be fabricated from steel members with adequate bracing to support the platform and cab.

4.16.2

The buffer-striking member on the underside of the car must stop the elevator before the plunger reaches its down limit of travel.

4.16.3

Guide shoes to be solid slipper type with polyurethane inserts.

4.17 OVERSPEED GOVERNOR

Elevator to be equipped with an overspeed governor complete with tension weight and brackets; high strength wire rope and attachment fittings, all in conformance with the applicable code sections. The governor shall be traction driven, self-resetting, field adjustable and be provided with a means to seal the tripping speed.

4.18 CAR TOP INSPECTION STATION

Provide a car top inspection station consisting of a stop button and constant pressure Up and DOWN button. The car top control will override all other controls. Also provide a 110-volt GFI outlet socket and light.

4.19 WIRING

All wiring and electrical connections shall comply with applicable Codes, insulated wiring shall have flame retardant and moisture proof outer covering and shall be run in a conduit or electrical wireways. Traveling cables shall be flexible and suitably suspended to relieve strain.

4.20 FINISH

Electrostatically applied baked polyester gloss powder coating paint finish.

Part 5- Execution

5.1 EXAMINATION

All site dimensions shall be taken to ensure that tolerances and clearances have been maintained and meet local regulations.

5.2 PREPARATION

Pre-inspect the construction and service requirements for "Work by Others." These requirements will be included in drawings, diagrams, engineering data sheets and special instructions before the work commences.

Part 6- Warranty

6.0 WARRANTY

The elevator contractor shall provide three (3) months free service from date of approval by local authorities. The entire elevator and all component parts shall carry a LIMITED WARRANTY for a period of One (1) Year. The warranty shall be for the replacement at no cost of defective parts but shall not include the labor costs required to replace the defective part or parts.

Part 7 - Owner's Instruction & Manual

7.0 OWNER'S INSTRUCTION & MANUAL

After installation is completed, the contractor shall instruct the owner in the proper use, operation and maintenance requirements of the elevator. Instructions to also include emergency procedures and safety rules and precautions. The contractor shall also supply the owner with an Owner's Manual detailing the operating, safety, and maintenance procedures of the elevator.

