



SRE-2010E Outdoor Electra-Ride™ Elite **Stairway Elevator Technical Specifications**

rev: 07-01-2011
ILS-00797

MODEL NUMBER: SRE-2010E
U.S. F.D.A. CLASSIFICATION: Class II
CLASSIFICATION NUMBER: 890.5150
PRODUCT CODE: ILK
CSA C-US Listed: File Number 208135

PERFORMANCE STANDARDS:

ANSI/ASME: A18.1-1999 (Sec. 7) Safety Standards for Platform Lifts and Stairway Chairlifts
ANSI/ASME: A18.1-2003 (Sec. 7) Safety Standards for Platform Lifts and Stairway Chairlifts
ANSI/ASME: A18.1-2005 (Sec. 7) Safety Standards for Platform Lifts and Stairway Chairlifts
ANSI/ASME: A18.1-2008 (Sec. 7) Safety Standards for Platform Lifts and Stairway Chairlifts
CSA B613 Private Residence Lifts for Persons with Physical Disabilities
ANSI/ASME: CSA B44.1/ASME-A17.5 Elevator and Escalator Electrical Equipment

RATED LOAD: 400 lb (181 kg) maximum

NUMBER OF PASSENGERS: 1

CONSTRUCTION: exterior-grade powder coated steel with an e-coat undercoating; stainless steel and exterior-grade hardware; weatherized electronics and controls.

POWER SOURCE: 24VDC comprised of 2 each 7AH 12 volt sealed maintenance-free lead acid batteries; On/Off power switch to prevent battery drain over lengthy storage periods

CHARGER: 120VAC/1.5A, 24VDC/2A continuous monitoring, full primary cut off. Charger must be located inside to avoid the elements. All exterior wiring is low voltage (24V).

CHARGING SYSTEM: carriage charges at either end of rail on innovative watertight sliding contacts

DRIVE: 24VDC direct drive gear-motor, 2 pole rated .68 HP, 58:1 right angle self-locking worm gear box, 41.5 RPM on output shaft of gear box

FINAL DRIVE: integrated 8dp gear rack on rail with a spur gear on the gearbox output shaft

MOTOR CONTROLLER: custom 24 VDC PWM controller with acceleration ramping

BRAKING: dynamic motor braking through motor controller, self-locking worm gear box, and electro-mechanical motor brake.

CALL/SEND CONTROL: 2.4 GHz RF wireless control with interference suppression; momentary switching requiring a user to continuously hold the button to control unit; keyed controls standard

ARMREST CONTROL: 3-position, momentary rocker switch requiring user to continuously hold rocker switch to control unit; switch mounted under armrest; keyed control standard

Bruno Independent Living Aids, Inc., 1780 Executive Drive, P.O. Box 84, Oconomowoc, WI 53066
Phone (800) 882-8183 Fax (262) 953-5501

Any reproduction or other use of these materials without written permission of Bruno Independent Living Aids, Inc. is expressly prohibited.
Bruno Independent Living Aids, Inc. reserves the right to modify or make changes to these specifications at any time without notice.

SUPPORTS: clamps anchored to stair tread; normal rail position is 2" (50.8 mm) above step nose; number of clamps dependent on the length of rail; optional height-adjustable clamps available

ANGLE: adjustable from 0 to 45 degrees standard; custom to 50 degrees

SPEED: maximum top speed 25 ft/min (0.13 m/s); actual speed varies depending on rider weight

LENGTH OF TRACK: 16 feet (4.9 m) and 20 feet (6.1 m) standard; dealer to cut to fit the actual length of the stair (see application guide); custom lengths available

TRACK CONSTRUCTION: aluminum extruded rail with covered steel gear rack; bolted joint plate at each rail joint

FOOTREST: folding footrest with safety sensor panel, adjustable height settings and handle actuator

SEAT: padded marine grade vinyl, folding and swivel with stops at 45° (bottom), 0° (forward), 60° (top), and 90° (top); multiple-position seat height adjustments

ARMRESTS: fixed to seat frame; armrest may be individually rotated towards seat back for smaller profile when not in use and to facilitate transfers; width adjustment of armrests: 4" (102 mm)

CANOPY: dual-lever, weather-resistant cover

SAFETY EQUIPMENT:

- 1) seat swivel switch allowing operation only when chair is in center position.
- 2) carriage and footrest safety switches
- 3) retractable seat positioning belt
- 4) charging light (green) on carriage; charging light (amber) at each end of rail
- 5) 30A manual reset breaker on motor control circuit
- 6) 5A fuse on control circuits
- 7) final end stop bumper at each end of rail
- 8) final limit switch
- 9) full diagnostic interconnect circuit board

BATTERY CAPACITY/POWER OUTAGE:

cycles: variable depending on angle, length of run, ambient temperature and rider weight
batteries: between 28 and 36 hours if power is disconnected

WEIGHT OF UNIT:

300 lb (136 kg) without rider in a typical 16 foot (4.9 m) installation

TESTING PERFORMED:

- 1) life cycle testing with full rated load at 45° on a 16-foot (4.9 m) rail
- 2) battery charger UL tested and listed to standard UL1012
- 3) self-locking gear box statically tested with 3200 lb (1451 kg) (8 times rated load) on a 45-degree rail for 5 minutes with no carriage movement; test performed at manufacturer's location
- 4) repetitive tests performed to determine power outage cycling
- 5) electrical discharge to ground testing performed for FDA 510(k)
- 6) electrical enclosure IPX3 (IEC 529), providing protection against spraying water
- 7) recommended environmental operating temperature range: 0°F (-15°C) to 125°F (50°C)

COMMERCIAL PACKAGE: not available

**Bruno Independent Living Aids, Inc., 1780 Executive Drive, P.O. Box 84, Oconomowoc, WI 53066
Phone (800) 882-8183 Fax (262) 953-5501**

Any reproduction or other use of these materials without written permission of Bruno Independent Living Aids, Inc. is expressly prohibited.
Bruno Independent Living Aids, Inc. reserves the right to modify or make changes to these specifications at any time without notice.

TECHNICAL DATA/SPECIFICATION

MODEL: SRE-2010E OUTDOOR ELECTRA-RIDE ELITE
 RATED LOAD: 400 LBS, ONE PASSENGER
 POWER SOURCE: 24 VOLT DC COMPRISED OF (2) 7 AMP/HR 12 VOLT SEALED BATTERIES
 110 VOLT AC 1.5 AMP, 24 VOLT DC 2 AMP CONTINUOUS MONITORING CHARGER.
 DRIVE: 24 VOLT DC DIRECT DRIVE GEAR-MOTOR, 2 POLE RATED .68 HP, 58:1 RIGHT ANGLE SELF LOCKING GEARBOX, 41.5 RPM NO LOAD RPM OUTPUT SPEED.
 SUSPENSION: RACK & PINION - INTEGRATED 8DP GEAR RACK ON RAIL WITH A SPUR GEAR ON THE OUTPUT SHAFT OF THE GEAR BOX.
 BRAKING: DYNAMIC MOTOR BRAKING THROUGH THE MOTOR CONTROLLER, SELF LOCKING WORM GEAR, AND ELECTRO-MECHANICAL MOTOR BRAKE.
 CONTROLS: CONTINUOUS PRESSURE ROCKER SWITCH LOCATED ON THE ARM REST AND WALL MOUNTED CALL/SEND CONTROLS LOCATED AT BOTH THE TOP AND BOTTOM LANDINGS.
 ANGLES: 0 TO 45 DEGREES (SPECIALS UP TO 50 DEGREES) RIGHT OR LEFT HAND ORIENTATIONS.
 FINAL LIMIT SWITCH STANDARD
 KEYED CALL/SEND CONTROLS STANDARD
 KEYED CONTROL ON CHAIR STANDARD

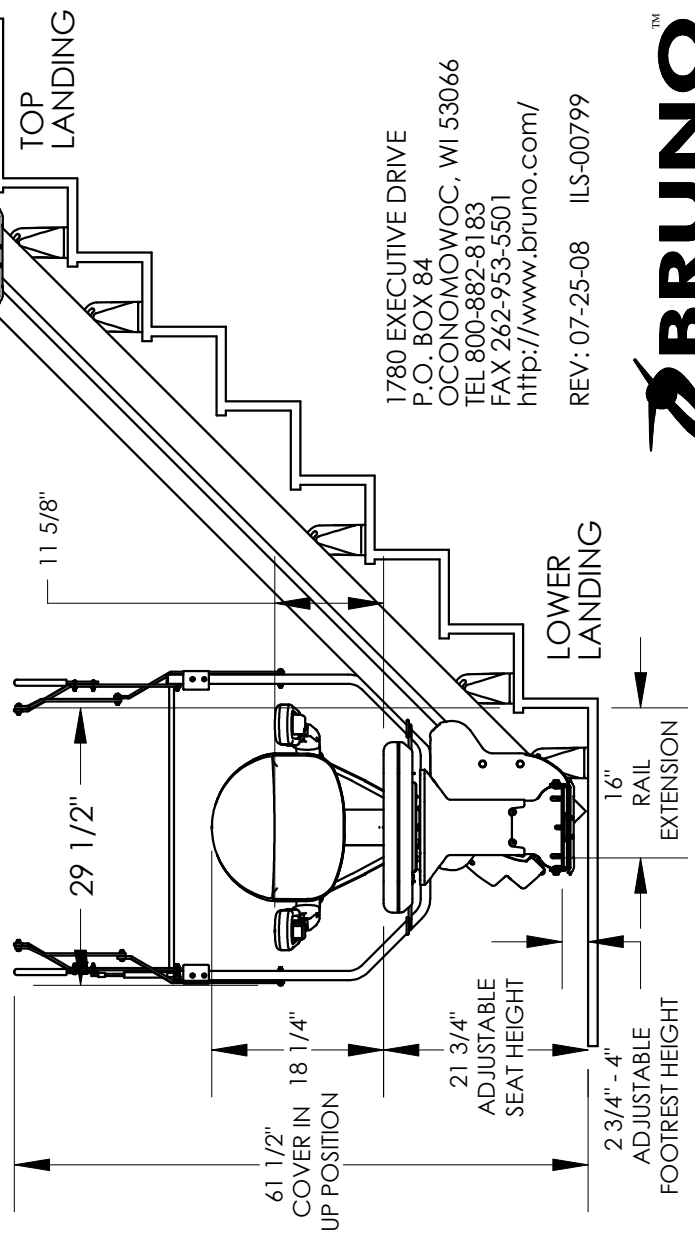
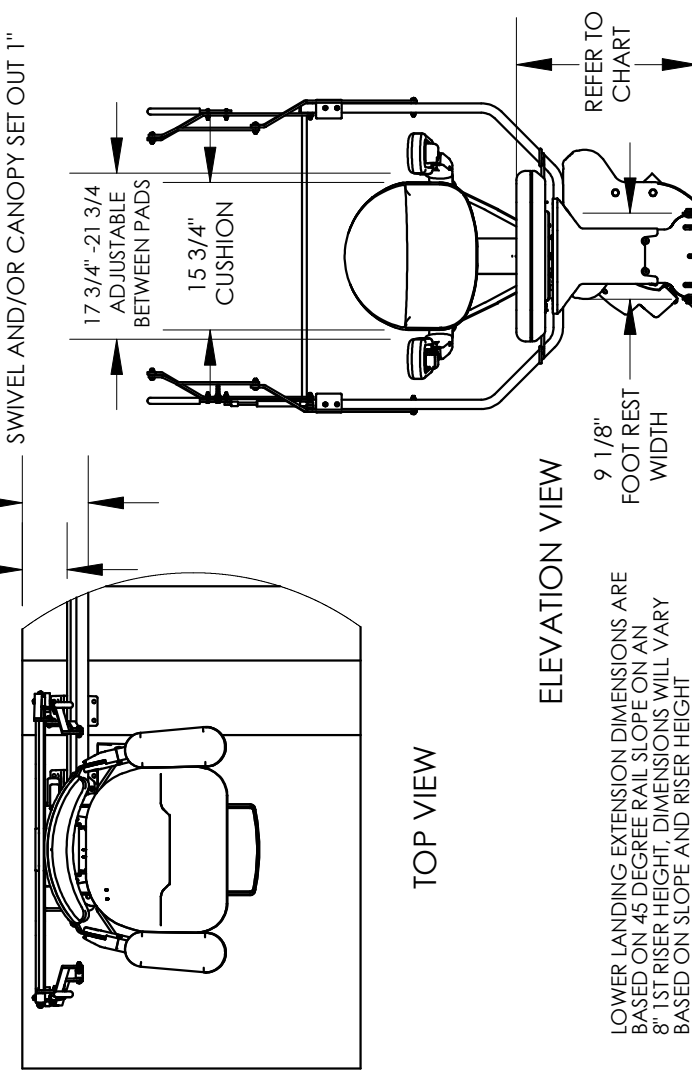

1780 EXECUTIVE DRIVE
 P.O. BOX 84
 OCONOMOWOC, WI 53066
 TEL 800-882-8183
 FAX 262-953-5501
<http://www.bruno.com/>

REV: 07-25-08 ILS-00799